



Created With Love



ABKANT VE PUNCH PRESS TAKIMLARI

EAST GATE PROJECT MAKİNE SANAYİ TİCARET LİMİTED ŞİRKETİ

ADRES: İhlamurkuyu Mah. Didenur Sk. No:1/7 34771 Ümraniye / İSTANBUL

TEL: +90 507 651 36 66 WEB: www.egp-universe.com

ÖNSÖZ

EGP mükemmeliyetçilik çerçevesinde sac işleme sektöründeki deneyimini, yüksek teknolojiye sahip makineleri ve ekip çalışmasını benimsemiş teknik kadrosuyla, abkant press'i sac kıvrıma kalıplarının imalatı konusunda siz değerli müşterilerimize uzun yıllar hizmet vermek amacıyla kurulmuştur.

KALİTE ANLAYIŞIMIZ

En ekonomik, en kullanışlı ulusal ve uluslararası teknik standartlara uygun satış ve satış sonrası hizmet devamlılığı ile müşteri memnuniyetini en üst seviyede tutmak.

MİSYON

Müşterilerimizin tüm ürün ve hizmet beklentilerini karşılamak için kendimizi sürekli geliştirerek her zaman daha iyi çözümler sunmak.

VİZYON

Sac işleme sektöründe öncü çözüm ve hizmetleriyle fark yaratan, Türkiye'de lider, uluslararası pazarda söz sahibi olmak.

İÇİNDEKİLER

DURMAZLAR TİPİ	SAYFA 1
ERMAKSAN TİPİ	SAYFA 1
BAYKAL TİPİ	SAYFA 1
İNANLAR TİPİ	SAYFA 1
MVD TİPİ	SAYFA 1
DENER TİPİ	SAYFA 1
CEMATEK TİPİ	SAYFA 1
HACO TİPİ	SAYFA 1
PROMECAM-AMADA TYPE	SAYFA 1
TRUMPF-WILA TYPE	SAYFA 27
BEYELER TYPE	SAYFA 35
GASPARINI TYPE	SAYFA 42
COLGAR TYPE	SAYFA 44
LVD-WILA TYPE	SAYFA 46
COLLY TYPE	SAYFA 52
AJIAL-AXIAL TYPE	SAYFA 56
HAMMERLE-BYSTRONIC TYPE	SAYFA 57
ÖZEL ABKANT TAKIMLARI	SAYFA 61
AKSESUARLAR	SAYFA 64
GIYOTİN KESME BIÇAKLARI	SAYFA 65
GÜÇLENDİRME	SAYFA 66

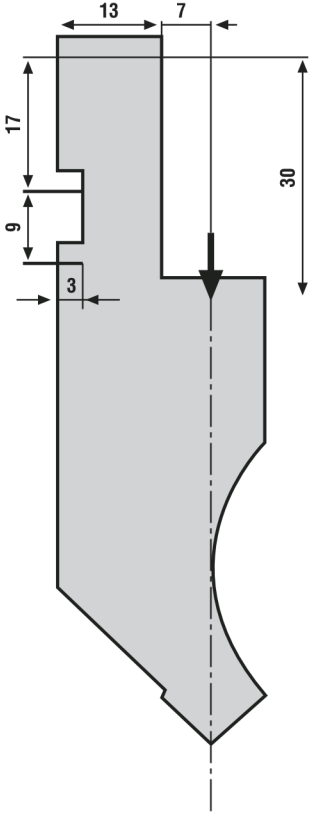

ÜST BAĞLANTI

Yanda teknik resmi bulunan kalıp, standart bağlantı ölçülerini göstermektedir.

Üretimini yapmış olduğumuz farklı bağlantı tipleride mevcuttur.

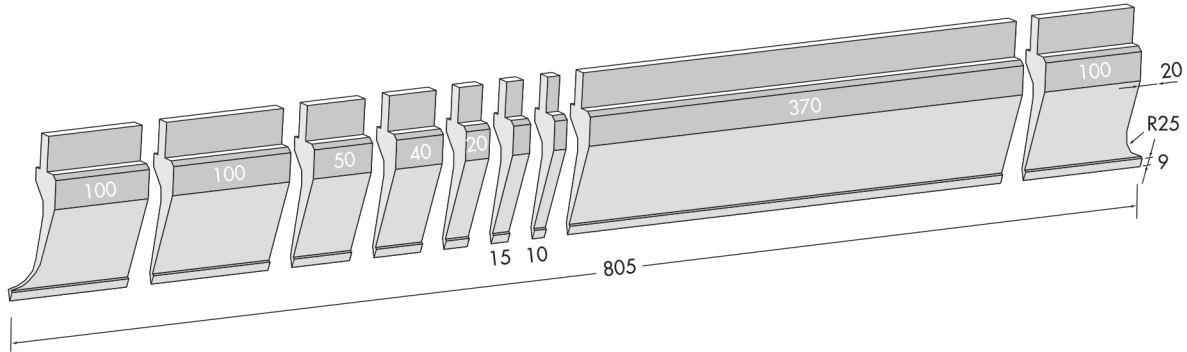
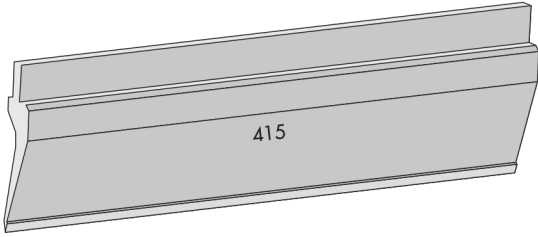

PROMECAM-AMADA TYPE

RKS-01-TO.205-85-(R08-R2)-835

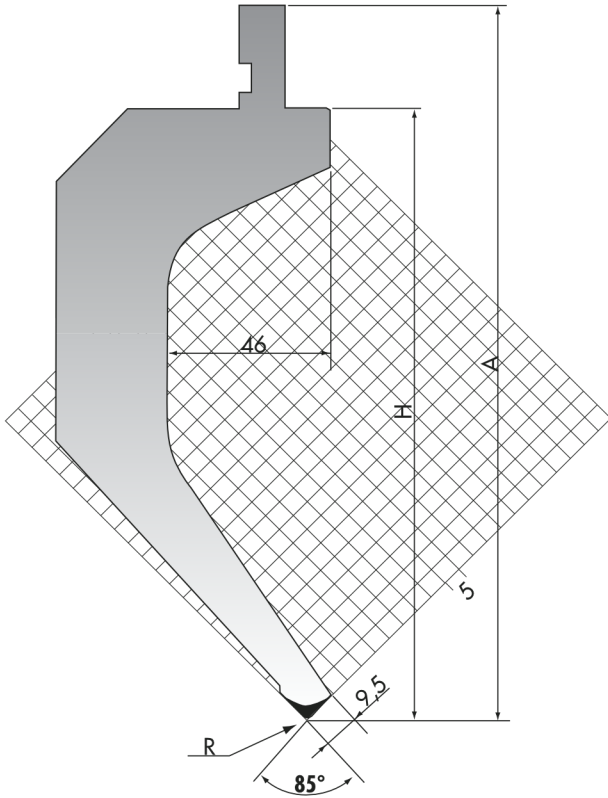

	H mm	A mm	R mm	max t/m
205-85-R08	175	205	0,8	70
205-85-R2	174,3	204,3	2	70

RKS-01-TO.175-85-(R08-R2)-835

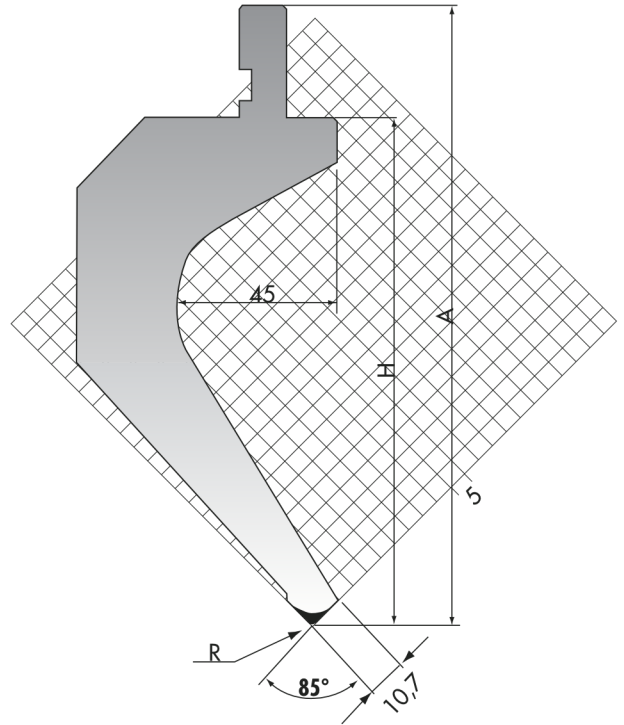

	H mm	A mm	R mm	max t/m
175-85-R08	145	175	0,8	90
175-85-R2	144,3	174,3	2	90

RKS-01-TO.175-85-R08-S-835

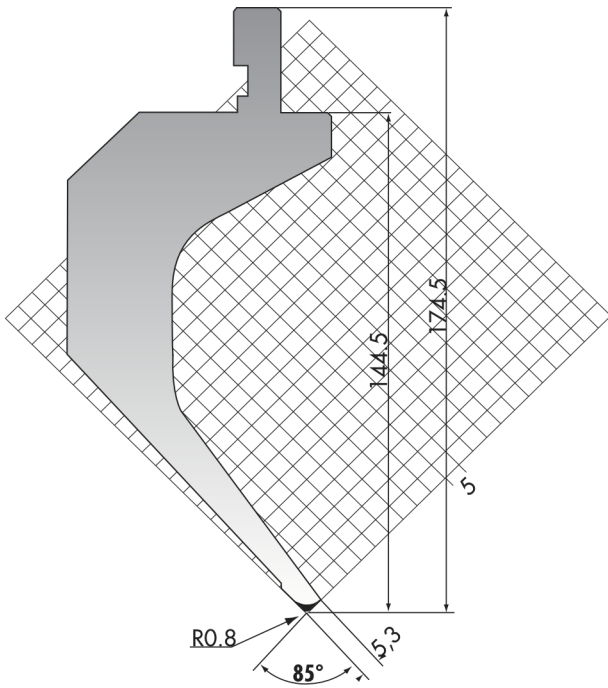

	max t/m
175-85-R08-S	20

RKS-01-TO.175-75-(R08-R2)-835

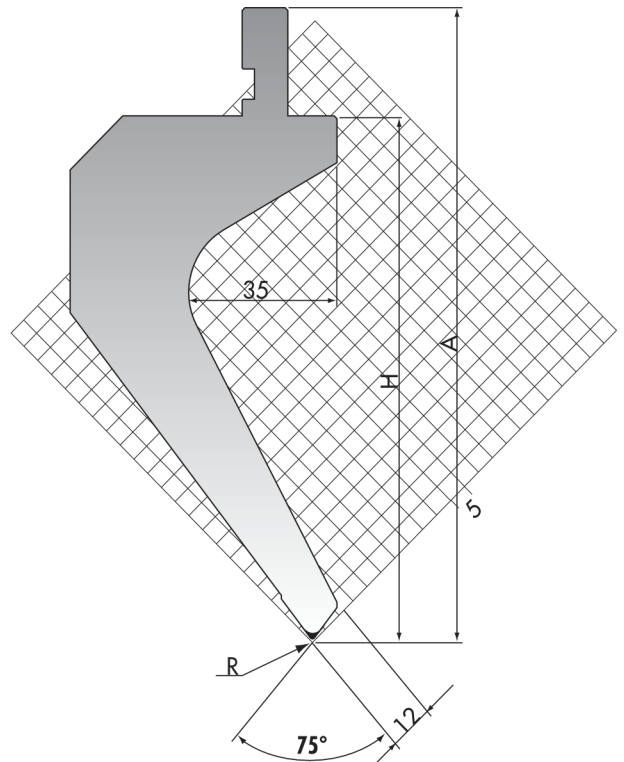

	H mm	A mm	R mm	max t/m
175-75-R08	145	175	0,8	75
175-75-R2	144,2	174,2	2	75

PROMECAM-AMADA TYPE

RKS-01-TO.175-60-(R08-R2)-835

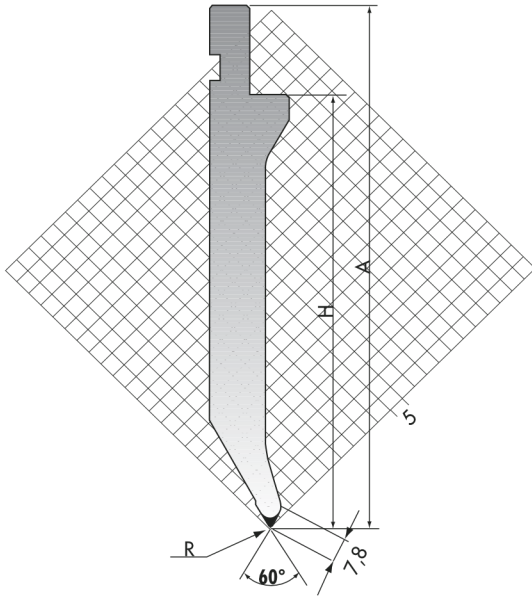

	H mm	A mm	R mm	max t/m
175-60-R08	145	175	0,8	80
175-60-R2	143,8	173,8	2	80

RKS-01-TO.175-60-R5-835

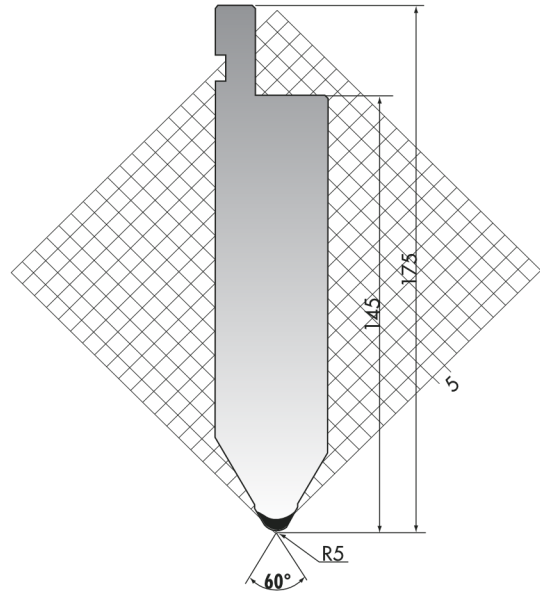

	max t/m
175-60-R5	160

RKS-01-TO.205-26-R08-835

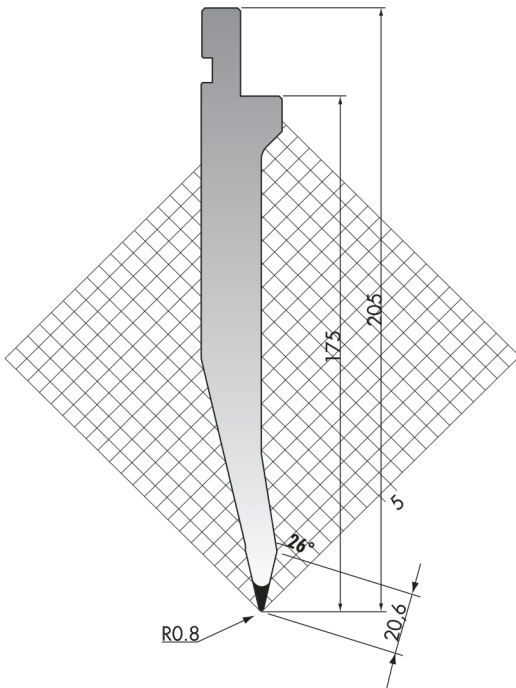

	max t/m
205-26-R08	95

RKS-01-TO.175-26-R08-835

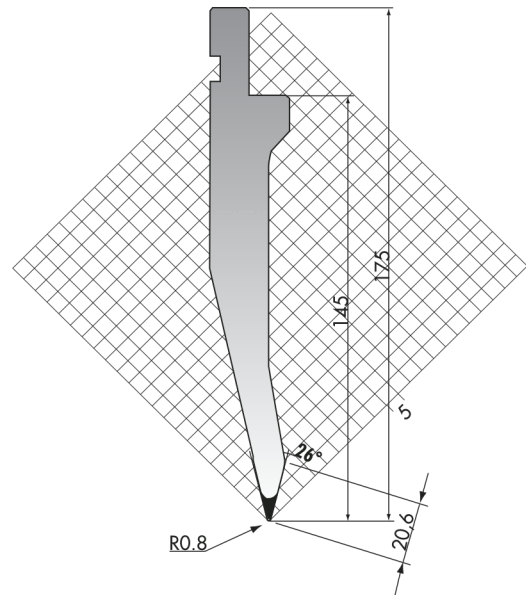

	max t/m
175-26-R08	95

PROMECAM-AMADA TYPE

RKS-01-PK.97-90-R06-835

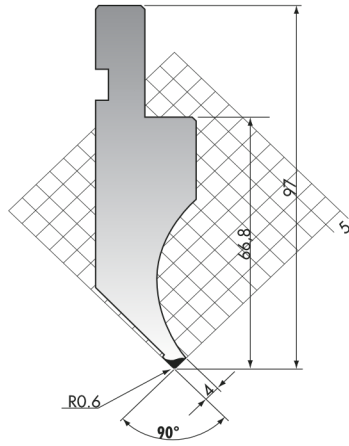

	max t/m
97-90-R06	35

RKS-01-PK.97-90-(R08-025)-835

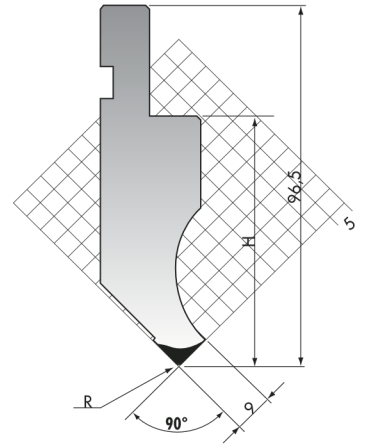

	H mm	R mm	max t/m
97-90-R08	66,35	0,8	100
97-90-R025	66,6	0,25	100

RKS-01-PK.114-90-R06-835

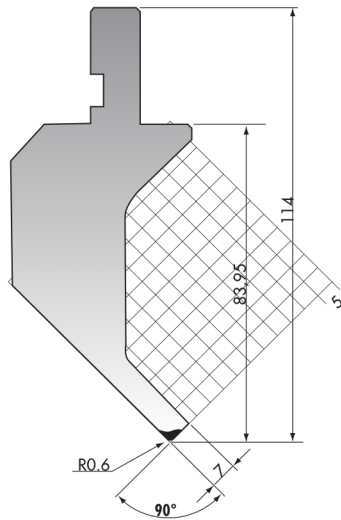

	max t/m
114-90-R06	20

RKS-01-PK.116-90-R08-835

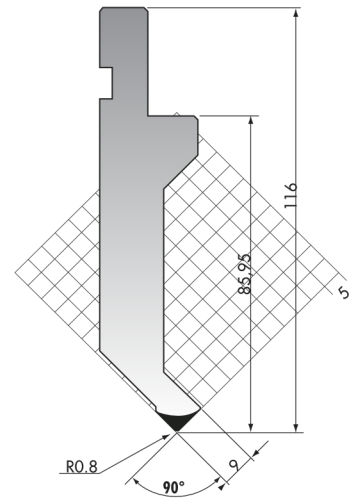

	max t/m
116-90-R08	40

RKS-01-DK.116-90-R08-835

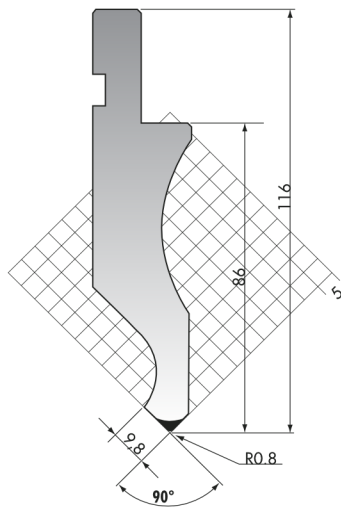

	max t/m
116-90-R08	50

RKS-01-PK.120-90-(R08-R025)-835

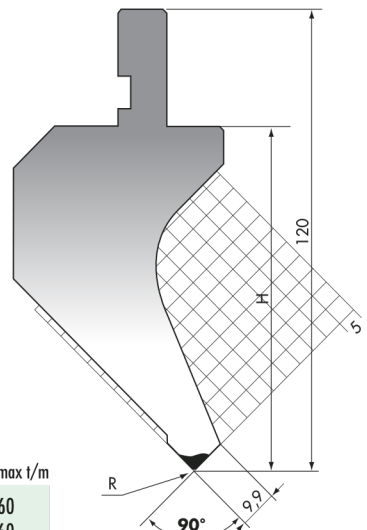

	H mm	R mm	max t/m
120-90-R08	89,35	0,8	60
120-90-R025	89,6	0,25	60

PROMECAM-AMADA TYPE

RKS-01-PK.135-90-(R08-R025)-835

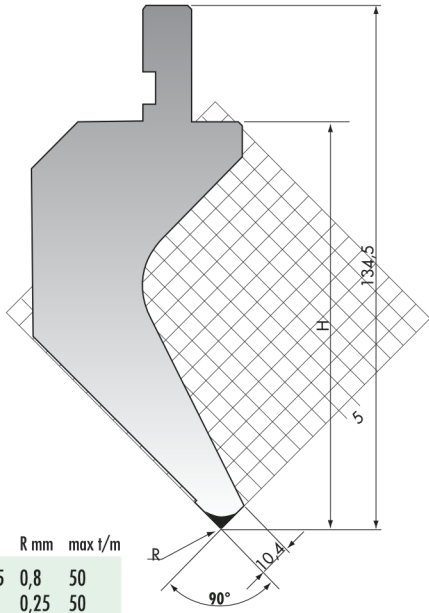

	H mm	R mm	max t/m
135-90-R08	104,35	0,8	50
135-90-R025	104,6	0,25	50

RKS-01-P.95-88-R3-835

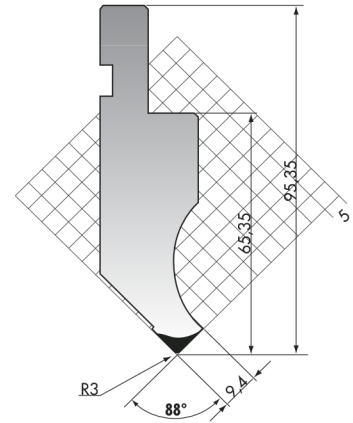

	max t/m
95-88-R3	100

RKS-01-P.97-88-R06-835

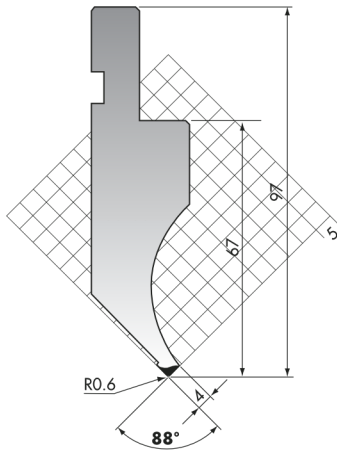

	R mm	max t/m
97-88-R06	0,6	35

RKS-01-P.97-88-(R08-R025)-835

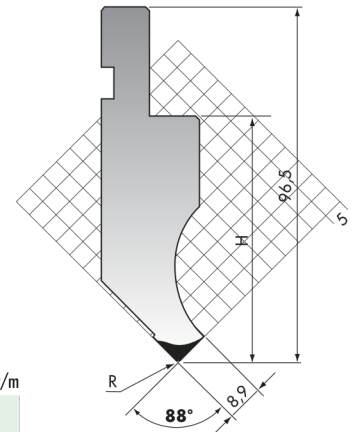

	H mm	R mm	max t/m
97-88-R08	66,65	0,8	100
97-88-R025	66,6	0,25	100

RKS-01-P.114-88-R06-835

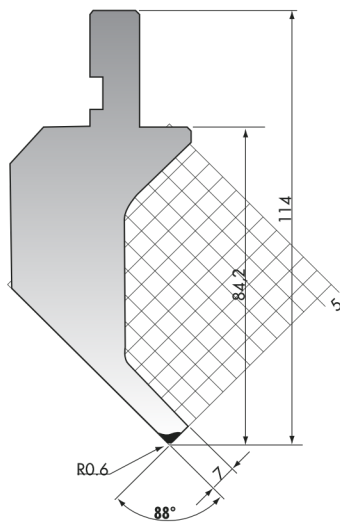

	max t/m
114-88-R06	20

RKS-01-P.116-88-R08-835

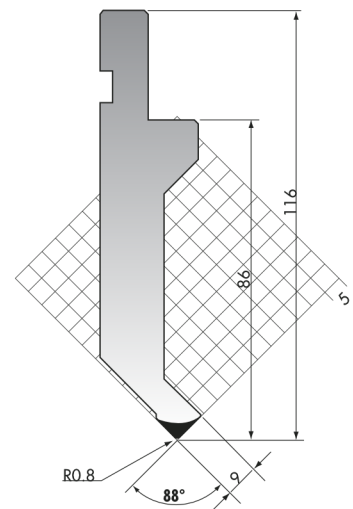

	max t/m
116-88-R08	40

PROMECAM-AMADA TYPE

RKS-01-D.116-88-(R08-R3)-835

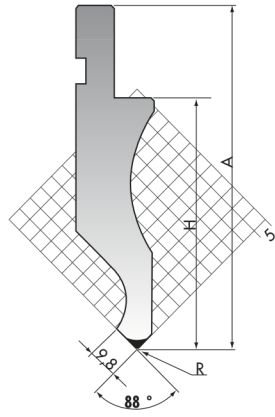

	H mm	A mm	R mm	max t/m
116-88-R08	86	116	0,8	50
116-88-R3	85	115	3	50

RKS-01-P.120-88-(R08-R3-R025)-835

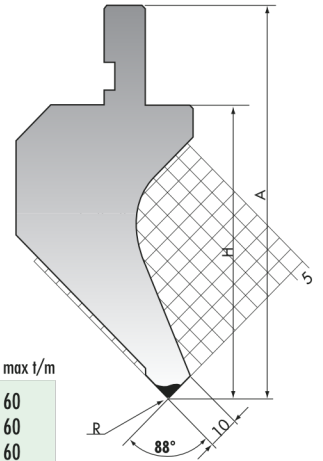

	H mm	A mm	R mm	max t/m
120-88-R08	89,65	120	0,8	60
120-88-R3	88,5	118,5	3	60
120-88-R025	89,6	120	0,25	60

RKS-01-P.135-88-(R08-R3-R025)-835

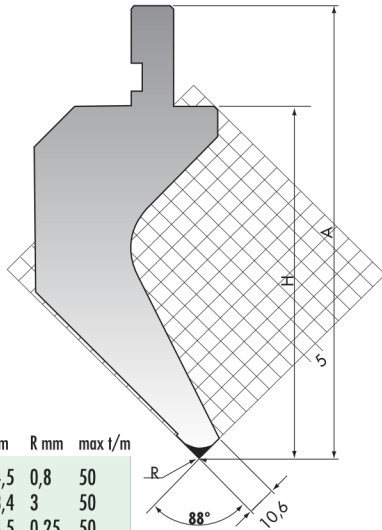

	H mm	A mm	R mm	max t/m
135-88-R08	104,65	134,5	0,8	50
135-88-R3	103,4	133,4	3	50
135-88-R025	104,6	134,5	0,25	50

RKS-01-P.125-88-R025-835

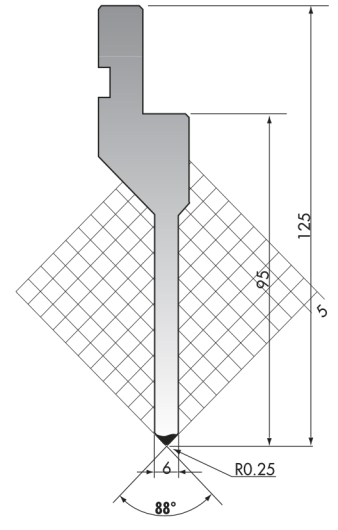

	max t/m
125-88-R025	50

RKS-01-P.150.88.R025-L-900

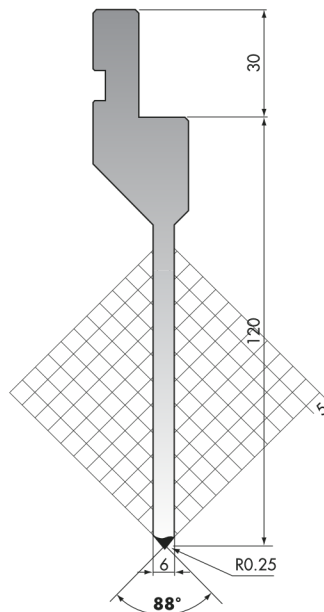

	max t/m
150-88-R025-L	50

RKS-01-P.150.88.R06-L-900

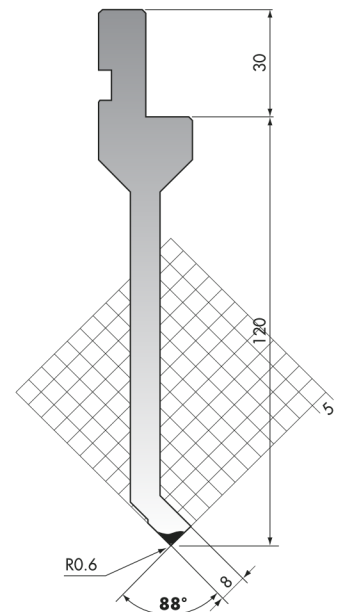

	max t/m
150-88-R06-L	35

PROMECAM-AMADA TYPE

RKS-01-P.130-88-(R06-025)-835

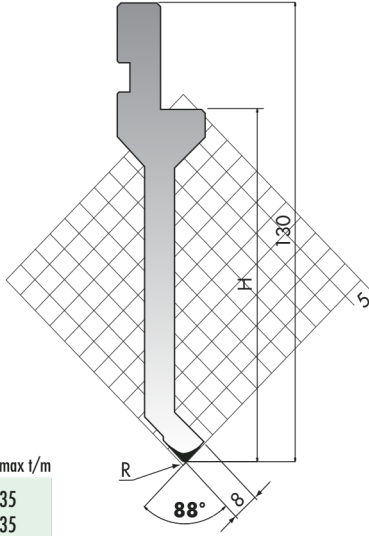

	R mm	H mm	max t/m
130-88-R06	0,6	100	35
130-88-R025	0,25	99,95	35

RKS-01-P.130-88-(R08-R025)-835

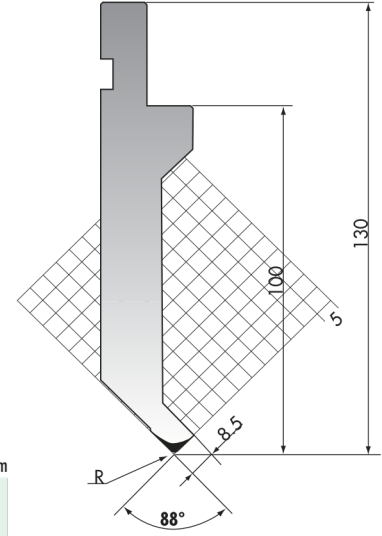

	R mm	max t/m
130-88-R08	0,8	40
130-88-R025	0,25	40

RKS-01-PS.135-88-R08-835

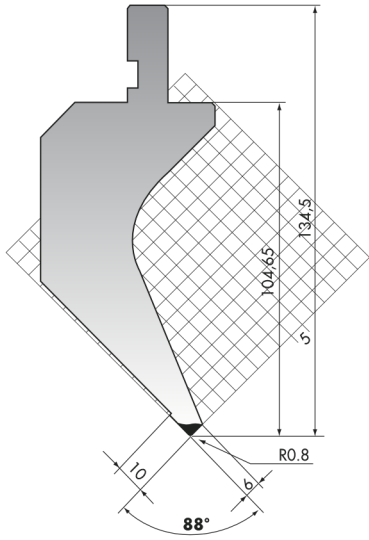

	max t/m
135-88-R08	45

RKS-01-PR.135-88-R08-835

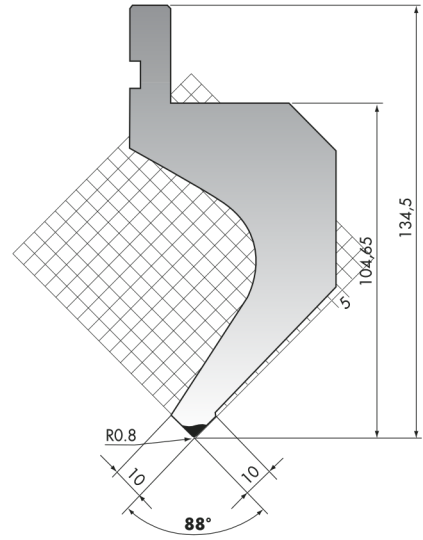

	max t/m
135-88-R08	45

RKS-01-P.150-88-(R08-R3)-835

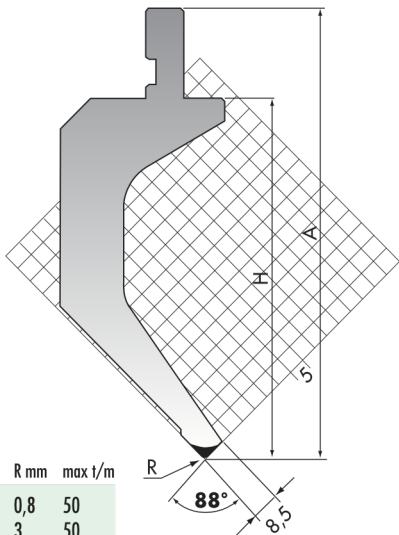

	H mm	A mm	R mm	max t/m
150-88-R08	120	150	0,8	50
150-88-R3	119	149	3	50

RKS-01-P.175-88-R08-835

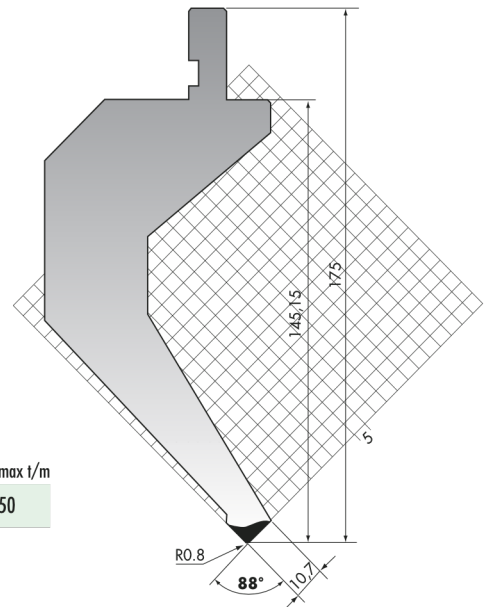

	max t/m
175-88-R08	50

PROMECAM-AMADA TYPE

RKS-01-P.196-88-R06-835

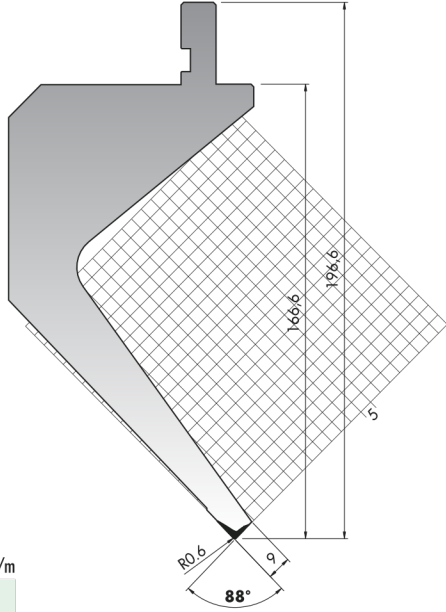

max t/m
196-88-R06 30

RKS-01-P.97-85-R08-835

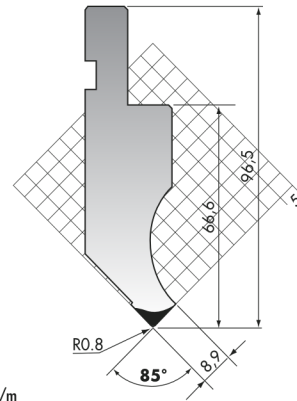

max t/m
97-85-R08 100

RKS-01-PK.120-85-R08-835

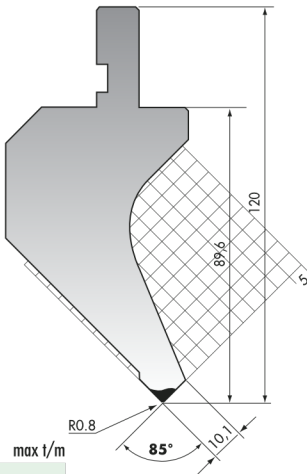

max t/m
120-85-R08 60

RKS-01-PK.135-85-R08-835

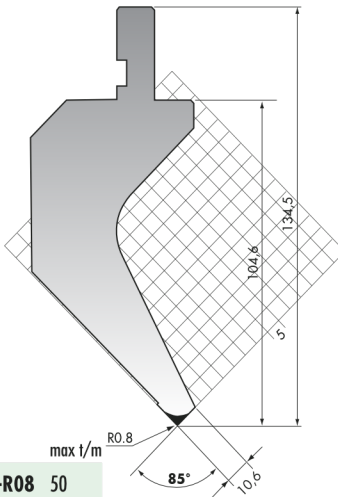

max t/m
135-85-R08 50

RKS-01-P.135-85-R08-835

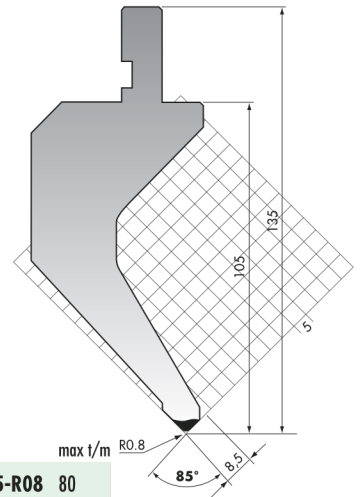

max t/m
135-85-R08 80

RKS-01-PS.135-85-R08-835

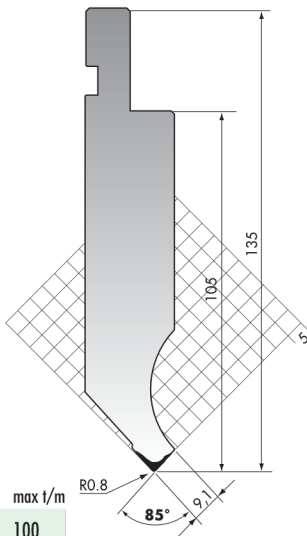

max t/m
135-85-R08 100

RKS-01-P.145-85-R08-835

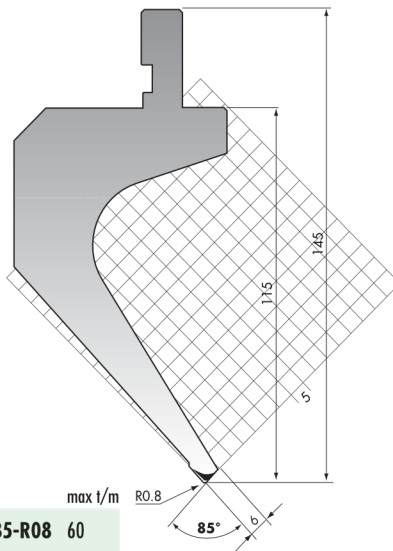

max t/m
145-85-R08 60

RKS-01-P.97-75-R08-835

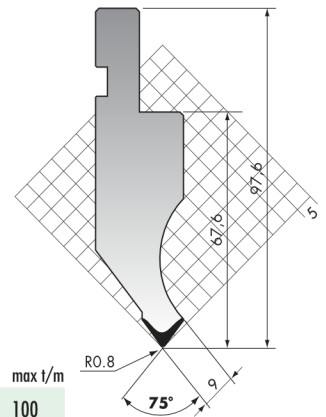

max t/m
97-75-R08 100

PROMECAM-AMADA TYPE

RKS-01-P.135-75-R08-835

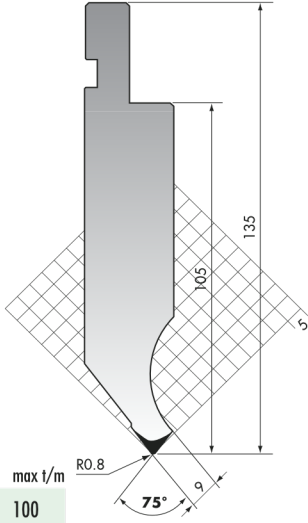

max t/m
135-75-R08 100

RKS-01-P.160-70-(R08-R3)-835

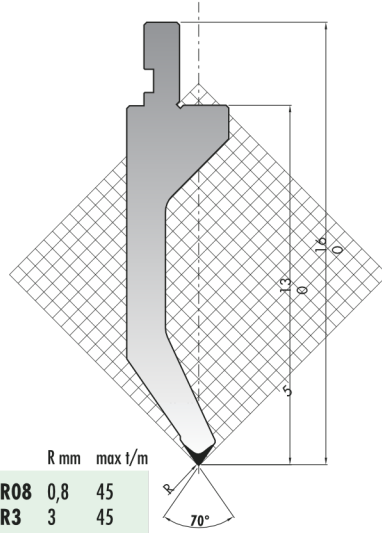

	R mm	max t/m
160-70-R08	0,8	45
160-70-R3	3	45

RKS-01-P.190-60-R08-835

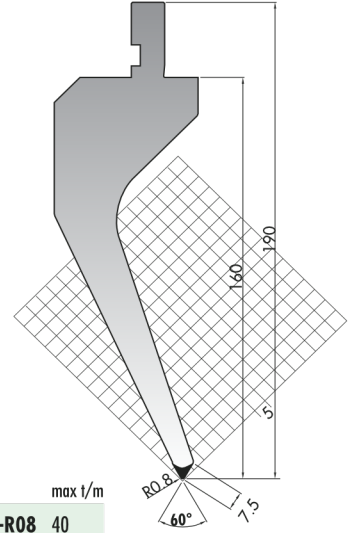

max t/m
190-60-R08 40

RKS-01-P.97-60-(R08-R2)-835

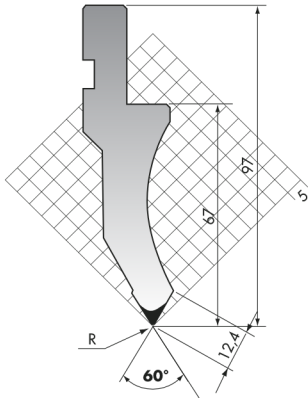

	R mm	max t/m
97-60-R08	0,8	60
97-60-R2	2	60

RKS-01-P.115-60-R08-835

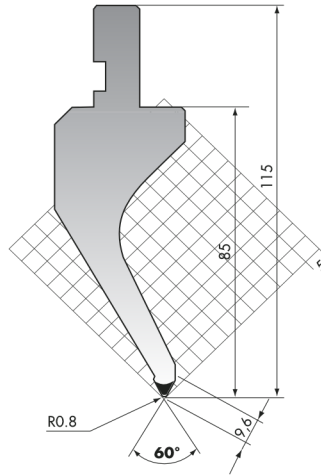

max t/m
115-60-R08 40

RKS-01-P.135-60-R08-835

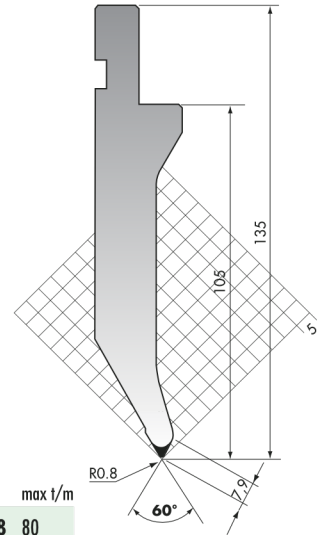

max t/m
135-60-R08 80

RKS-01-PG.135-60-R08-835

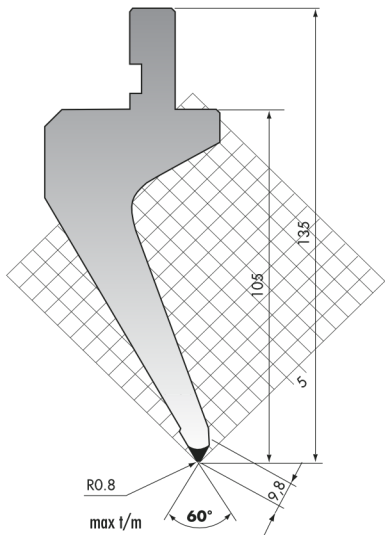

max t/m
135-60-R08 70

RKS-01-P.145-60-R08-835

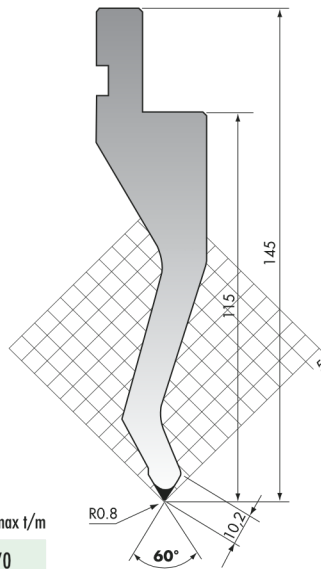

max t/m
145-60-R08 70

RKS-01-P.130-45-R6-835

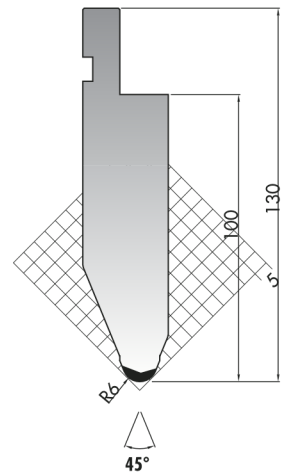

max t/m
130-45-R6 100

PROMECAM-AMADA TYPE

RKS-01-P.97-45-R05-835

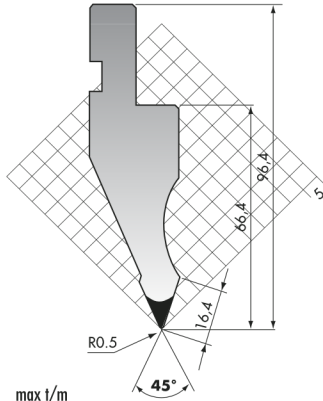

max t/m
97-45-R05 80

RKS-01-P.95-45-(R08-R15)-835

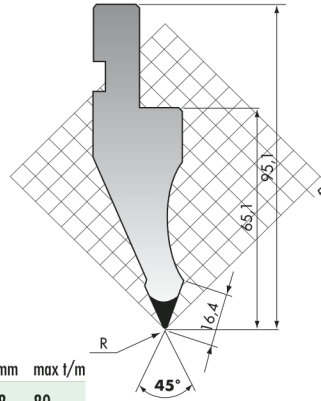

	R mm	max t/m
95-45-R08	0,8	80
95-45-R15	1,5	80

RKS-01-P.95-35-R5-835

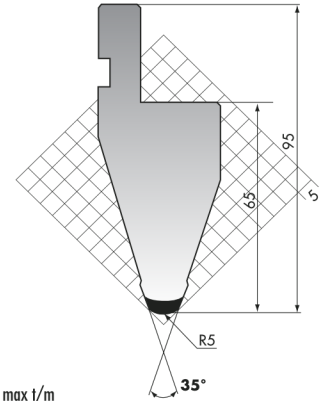

max t/m
95-35-R5 100

RKS-01-PU.85-35-R08-835

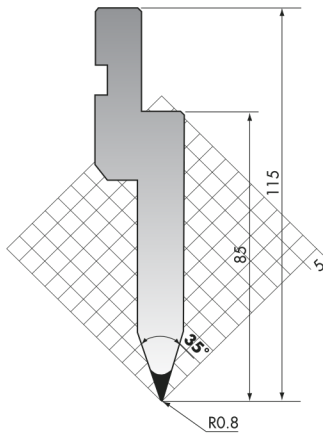

max t/m
85-35-R08 100

RKS-01-P.116-35-(R08-R15)-835

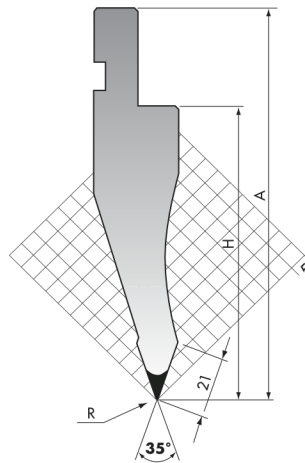

	H mm	A mm	R mm	max t/m
116-35-R08	86	116	0,8	70
116-35-R15	86	116	1,5	70

RKS-01-PS.134-30-R08-835

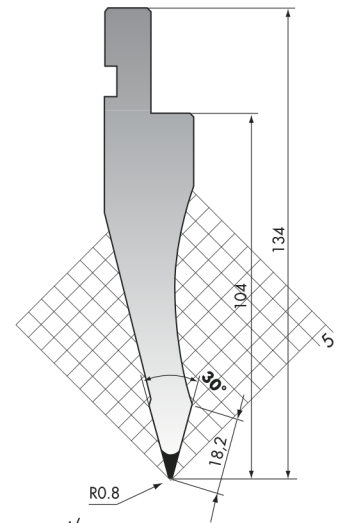

max t/m
134-30-R08 70

RKS-01-P.147-26-R08-835

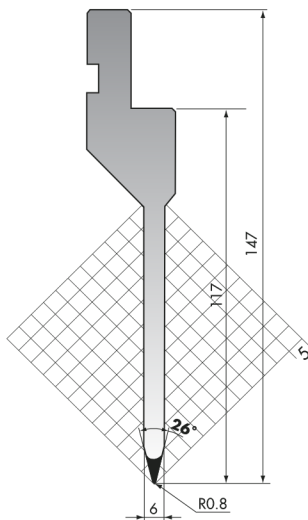

max t/m
147-26-R08 50

RKS-01-PU.150-26-R08-L-900

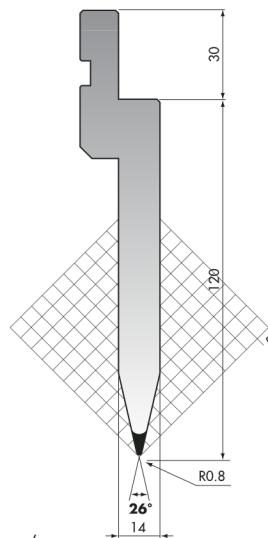

max t/m
150-26-R08-L 100

RKS-01-PU.117-26-(R08-R3)-835

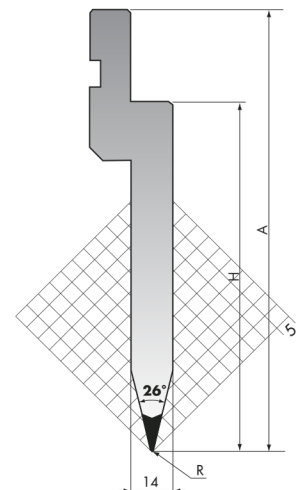

	R mm	H mm	A mm	max t/m
117-26-R08	0,8	117	147	100
117-26-R3	3	109	139	100

PROMECAM-AMADA TYPE

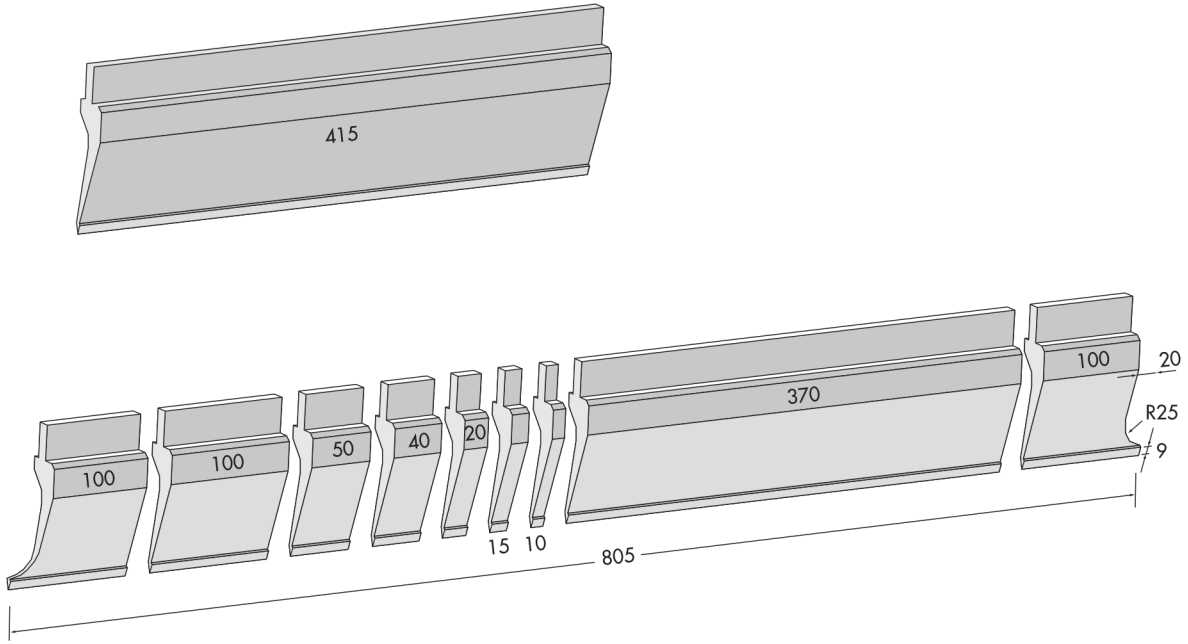

RKS-01-PU.67-14-S-830

RKS-01-C3 C7,5-835

RKS-01-PU.67-14-830

RKS-01-PU.87-14-830

RKS-01-PU.105-14-830

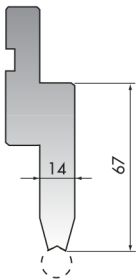

M4	
R mm	R mm
3	3,5
3,5	4
4	4,5
4,5	5
5	

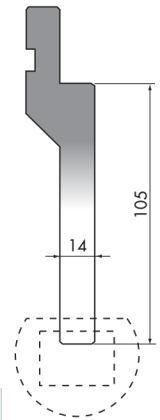
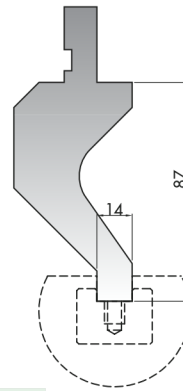
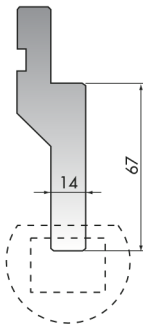

67-14-S

67-14

87-14

105-14

RKS-01-PU.115-14-830

RKS-E30-22-835

RKS-01-C13-08-835

RKS-01-C13-09-835

RKS-01-C16-10-835

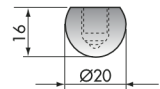
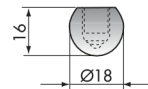
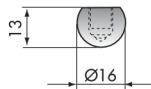
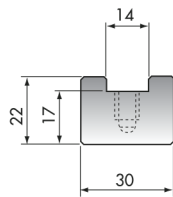
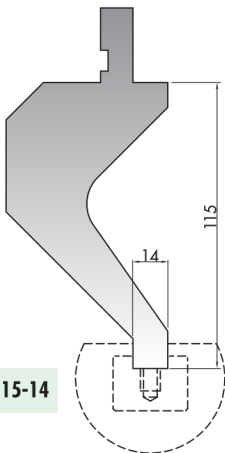

max t/m
30-22 80

max t/m
13-08 80

max t/m
13-09 80

max t/m
16-10 80

115-14

PROMECAM-AMADA TYPE

RKS-01-M460-88-85-835

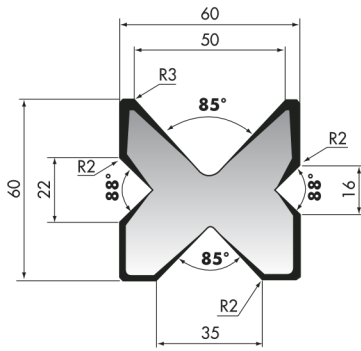

max t/m
460 80

RKS-01-M460-R-85-835

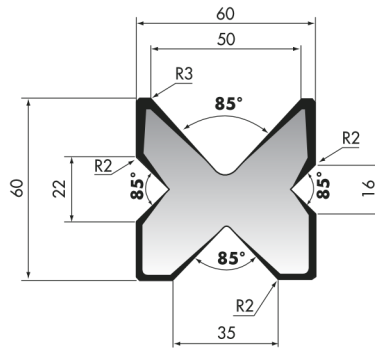

max t/m
460-R 80

RKS-01-M460-60-835

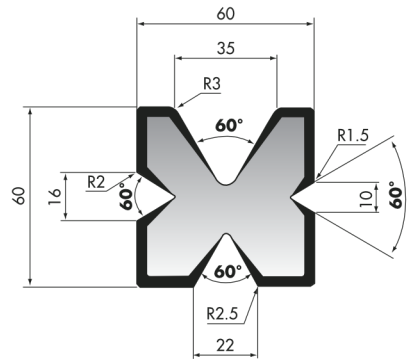

max t/m
460-60 60

RKS-01-M490-80-60-835

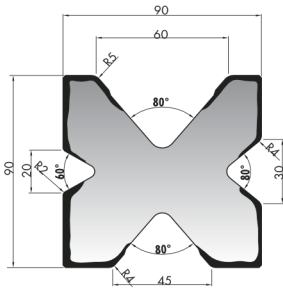

max t/m
490 100

RKS-01-M490-70-80-60-835

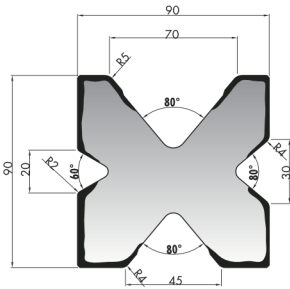

max t/m
490-70 100

RKS-01-M360R-835

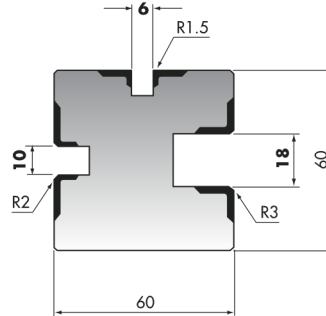

max t/m
360R 100

RKS-01-M60-90-01-835

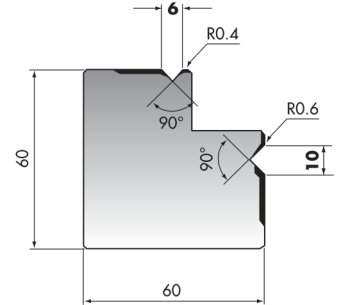

max t/m
60-90-01 100

RKS-01-M60-90-02-835

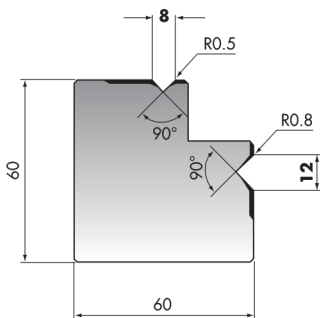

max t/m
60-90-02 80

RKS-01-M60-85-32-835

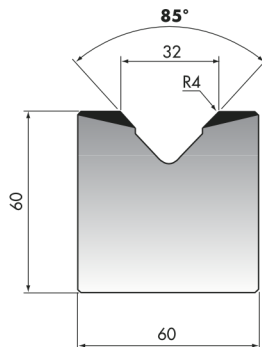

max t/m
60-85-32 100

RKS-01-M60-85-40-835

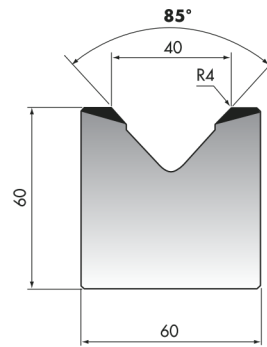

max t/m
60-85-40 100

RKS-01-M60-85-50-835

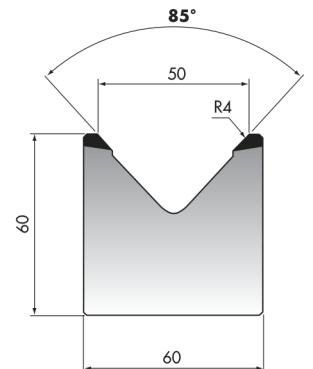

max t/m
60-85-50 100

PROMECAM-AMADA TYPE

RKS-01-M75-85-63-835

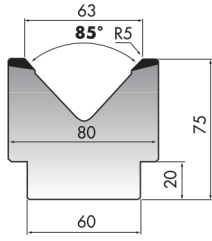

max t/m
75-85-63 100

RKS-01-M80-85-80-835

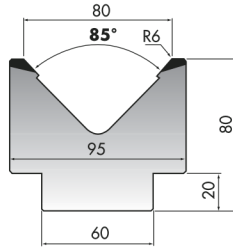

max t/m
80-85-80 100

RKS-01-M95-80-100-835

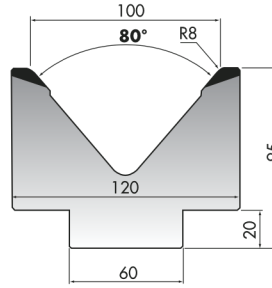

max t/m
95-80-100 100

RKS-01-M103-80-125-835

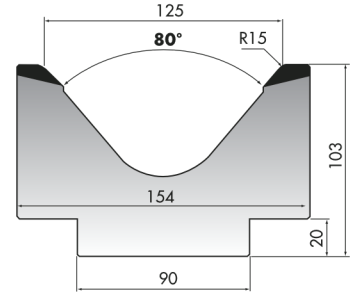

max t/m
103-80-125 100

RKS-01-M130-80-160-835

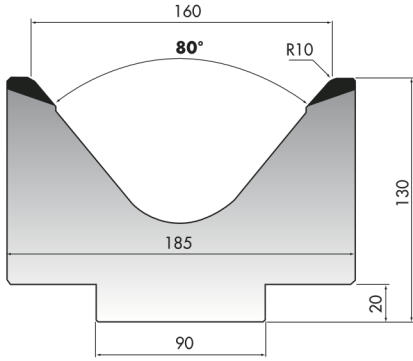

max t/m
130-80-160 100

RKS-01-M195-70-200-415

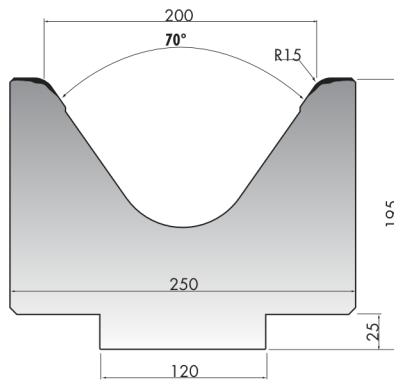

max t/m
195-70-200 180

RKS-01-M86-60-63-835

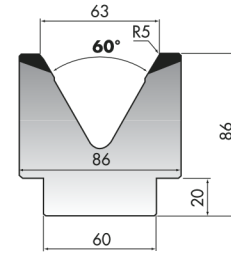

max t/m
86-60-63 100

RKS-01-M110-60-80-835

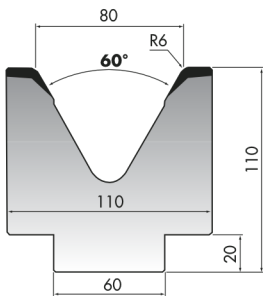

max t/m
110-60-80 100

RKS-01-M80-45-32-835

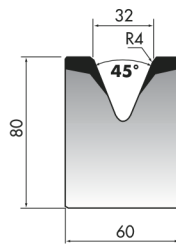

max t/m
80-45-32 100

RKS-01-M80-45-40-835

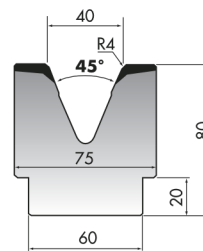

max t/m
80-45-40 100

RKS-01-M80-45-50-835

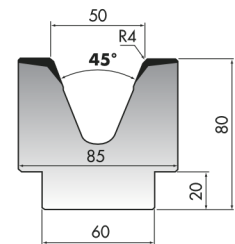

max t/m
80-45-50 95

PROMECAM-AMADA TYPE

RKS-01-T80-(06-08-10-12)-90-835

	V mm	R mm	S mm	max t/m
06-90	6	0,4	14	100
08-90	8	0,5	14	100

	V mm	R mm	S mm	max t/m
10-90	10	0,6	18	100
12-90	12	0,8	18	100

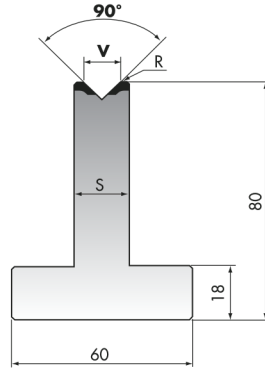

RKS-01-T80-(06-08-10-12-16-20-25)-835

	V mm	R mm	S mm	max t/m
06-88	6	0,4	14	100
08-88	8	0,5	14	100
10-88	10	0,8	18	100
12-88	12	2,75	18	100
16-88	16	2,75	24	100
20-88	20	3	30	100
25-88	25	3	35	100

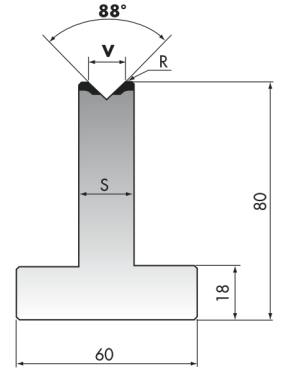

RKS-01-T80-(06-08-10-12-16-20-25)-80-835

	V mm	R mm	S mm	max t/m
06-80	6	2,75	14	95
08-80	8	2,75	14	95
10-80	10	2,75	18	95
12-80	12	2,75	18	95
16-80	16	2,75	24	95
20-80	20	3	30	95
25-80	25	3	35	95

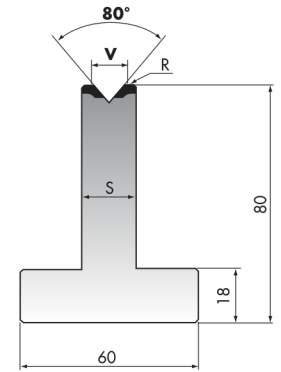

RKS-01-80-(06-08-10-12-16-20-25)-60-835

	V mm	R mm	S mm	max t/m
06-60	6	0,5	14	60
08-60	8	0,8	14	60
10-60	10	0,8	18	60
12-60	12	0,8	18	60
16-60	16	2,75	24	60
20-60	20	3	30	60
25-60	25	3	35	60

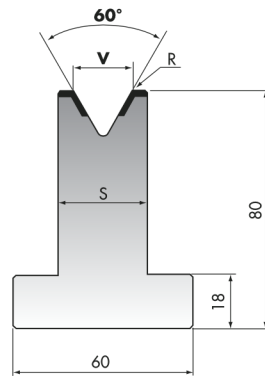

RKS-01-T80-(06-08-10-12-16-20-25)-45-835

	V mm	R mm	S mm	max t/m
06-45	6	0,8	14	50
08-45	8	1	18	50
10-45	10	1,2	18	50
12-45	12	1,6	24	50
16-45	16	2,75	26	50
20-45	20	3	30	50
25-45	25	3	37	50

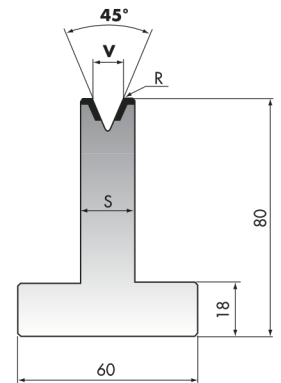

RKS-01-T80-(06-08-10-12-16-20-25)-35-835

	V mm	R mm	S mm	max t/m
06-35	6	0,8	14	35
08-35	8	1	16	35
10-35	10	1,2	20	40
12-35	12	1,6	22	40
16-35	16	3	30	45
20-35	20	3	35	50
25-35	25	3	40	50

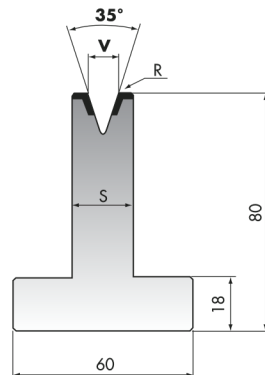

RKS-01-T80-(06-08-10-12-16-20-25)-30-835

	V mm	R mm	S mm	max t/m
06-30	6	0,6	14	35
08-30	8	0,8	18	35
10-30	10	1	24	50
12-30	12	1,5	24	40
16-30	16	2	30	45
20-30	20	2,5	35	50
25-30	25	3	40	50

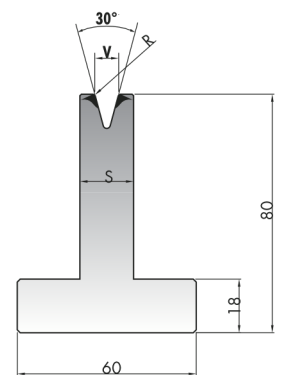

PROMECAM-AMADA TYPE

RKS-01-T80-(06-08-10-12)-26-835

	V mm	R mm	S mm	max t/m
06-26	6	0,8	16	20
08-26	8	1	20	20
10-26	10	1,2	24	20
12-26	12	1,6	26	20

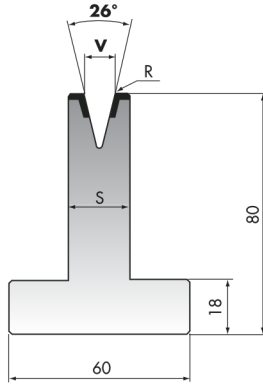

RKS-01-T120-(06-08-10-12)-90-835

	V mm	R mm	S mm	max t/m
06-90	6	0,4	14	100
08-90	8	0,5	14	100
10-90	10	0,6	18	100
12-90	12	0,8	18	100

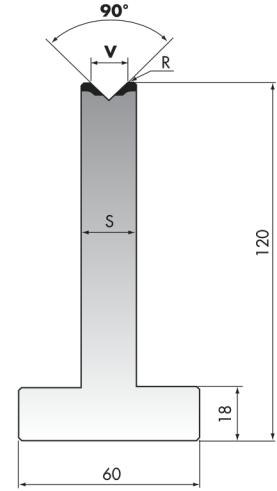

RKS-01-T120-(06-08-10-12-16-20-25)-88-835

	V mm	R mm	S mm	max t/m
06-88	6	0,4	14	100
08-88	8	0,5	14	100
10-88	10	0,8	18	100
12-88	12	2,75	18	100
16-88	16	2,75	24	100
20-88	20	3	30	100
25-88	25	3	35	100

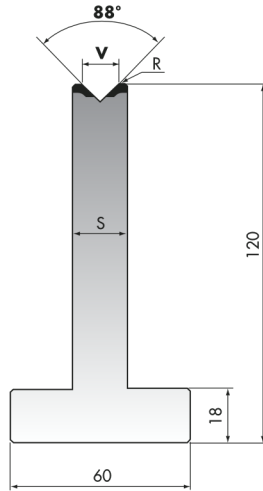

RKS-01-120-(06-08-10-12-16-20-25)-80-835

	V mm	R mm	S mm	max t/m
06-80	6	2,75	14	95
08-80	8	2,75	14	95
10-80	10	2,75	18	95
12-80	12	2,75	18	95
16-80	16	2,75	24	95
20-80	20	3	30	95
25-80	25	3	35	95

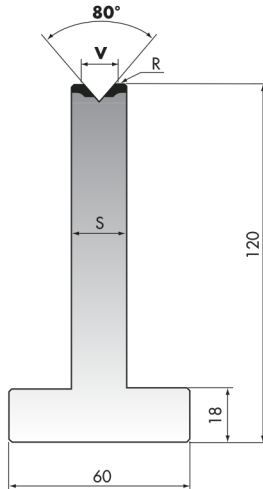

RKS-01-T120-(06-08-10-12-16-20-25)-60-835

	V mm	R mm	S mm	max t/m
06-60	6	0,5	14	60
08-60	8	0,8	14	60
10-60	10	0,8	18	60
12-60	12	0,8	18	60
16-60	16	2,75	24	60
20-60	20	3	30	60
25-60	25	3	35	60

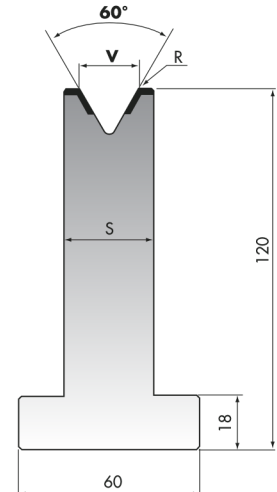

PROMECAM-AMADA TYPE

RKS-01-T120-(06-08-10-12-16-20-25)45-835

	V mm	R mm	S mm	max t/m
06-45	6	0,8	14	50
08-45	8	1	18	50
10-45	10	1,2	18	50
12-45	12	1,6	24	50
16-45	16	2,75	26	50
20-45	20	3	30	50
25-45	25	3	37	50

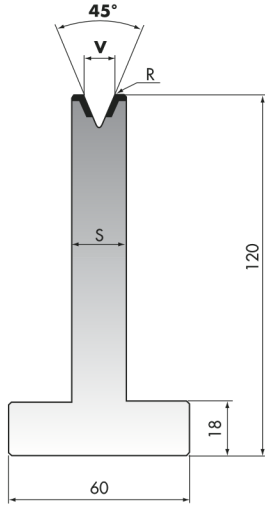

RKS-01-T120-(06-08-10-12-16-20-25)-35-835

	V mm	R mm	S mm	max t/m
06-35	6	0,8	14	35
08-35	8	1	16	35
10-35	10	1,2	20	40
12-35	12	1,6	22	40
16-35	16	3	30	45
20-35	20	3	35	50
25-35	25	3	40	50

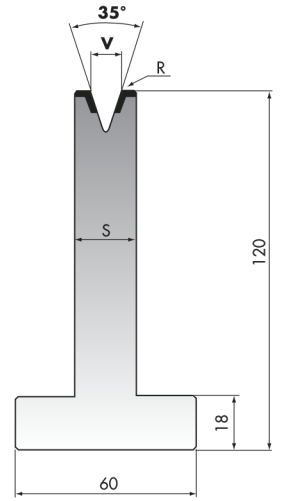

RKS-01-T120-(06-08-10-12-16-20-25)-30-835

	V mm	R mm	S mm	max t/m
06-30	6	0,6	14	35
08-30	8	0,8	18	35
10-30	10	1	24	50
12-30	12	1,5	24	40
16-30	16	2	30	45
20-30	20	2,5	35	50
25-30	25	3	40	50

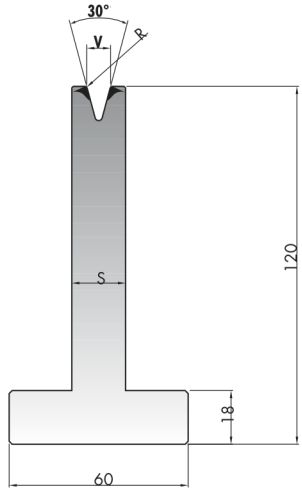

RKS-01-T120-(06-08-10-12)-26-835

	V mm	R mm	S mm	max t/m
06-26	6	0,8	16	20
08-26	8	1	20	20
10-26	10	1,2	24	20
12-26	12	1,6	26	20

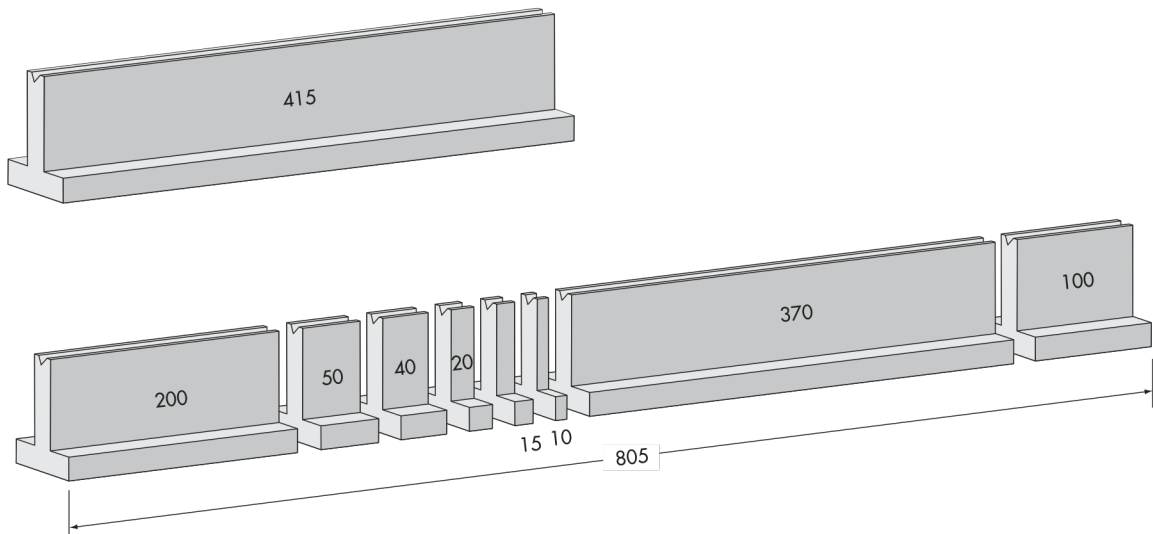
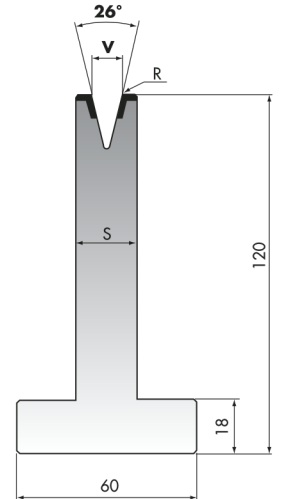

PROMECAM-AMADA TYPE

RKS-01-TN80-14 INS14-(06-08-10)-88/(06-08-10)-60/(06-08-10)-60/(06-08-10)-45/(06-08)-30-835

	A°	V mm
06-88	88	6
08-88	88	8
10-88	88	10
06-60	60	6
08-60	60	8
10-60	60	10
06-45	45	6
08-45	45	8
10-45	45	10
06-30	30	6
08-30	30	8

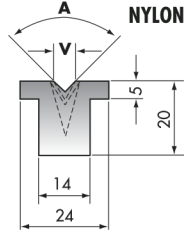

RKS-01-INS14

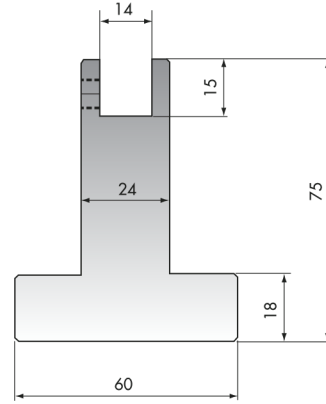

RKS-01-TN80-14

RKS-01-TN80-20 INS20-(06-08-10-12-16)-88/(06-08-10-12-16)-60/(06-08-10-12)-45/(06-08-10)-30-835

	A°	V mm
06-88	88	6
08-88	88	8
10-88	88	10
12-88	88	12
16-88	88	16
06-60	60	6
08-60	60	8
10-60	60	10
12-60	60	12
16-60	60	16

	A°	V mm
06-45	45	6
08-45	45	8
10-45	45	10
12-45	45	12
06-30	30	6
08-30	30	8
10-30	30	10

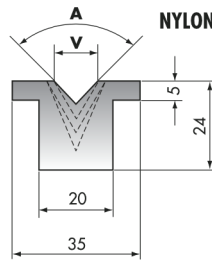

RKS-01-INS20

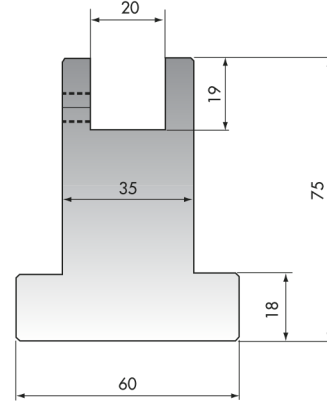

RKS-01-TN80-20

RKS-01-TN80-30 INS30-(06-08-10)-88/(06-08-10)-60/(06-08-10)-45/(06-08)-30-835

	A°	V mm
06-88	88	6
08-88	88	8
10-88	88	10
06-60	60	6
08-60	60	8
10-60	60	10
06-45	45	6
08-45	45	8
10-45	45	10
06-30	30	6
08-30	30	8

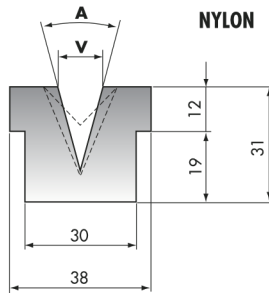

RKS-01-INS30

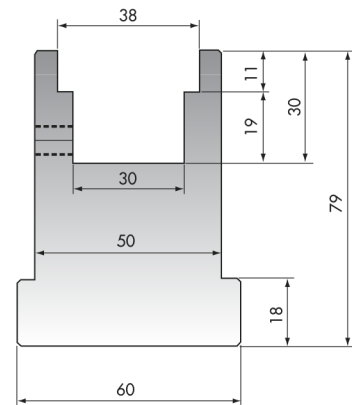

RKS-01-TN80-30

PROMECAM-AMADA TYPE

RKS-01-AMR60-(04-06-08-10-12-16-20-25)-88/(06-08-10-12-16-20)-30/AMR65-(25)-30-835

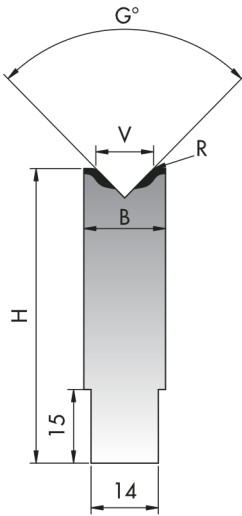

	V mm	G°	H mm	R mm	B mm	max t/m
04-88	4	88	60	0,6	14	100
06-88	6	88	60	0,8	14	100
08-88	8	88	60	1,0	14	100
10-88	10	88	60	1,2	18	100
12-88	12	88	60	1,5	18	100
16-88	16	88	60	2,0	24	100
20-88	20	88	60	2,0	30	100
25-88	25	88	60	3,0	35	100

06-30	6	30	60	0,6	14	35
08-30	8	30	60	0,8	18	35
10-30	10	30	60	1,0	24	50
12-30	12	30	60	1,5	24	40
16-30	16	30	60	2,0	30	45
20-30	20	30	60	2,5	35	50
25-30	25	30	65	3,0	45	50

RKS-01-AMR

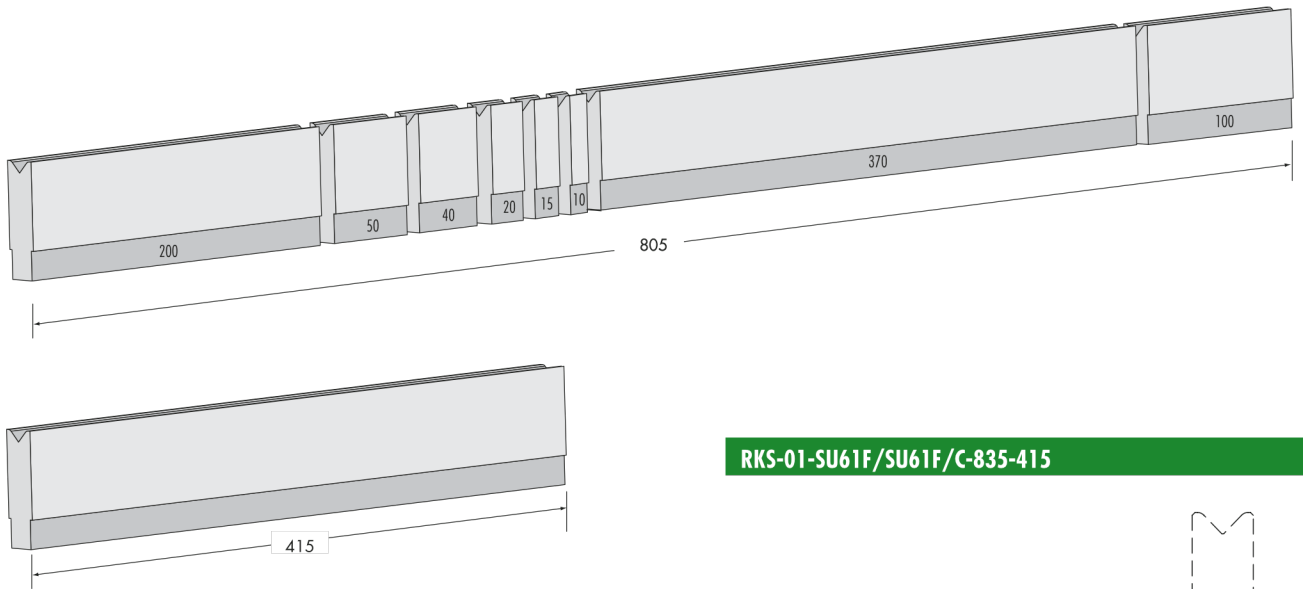

RKS-01-SU61F/SU61F/C-835-415

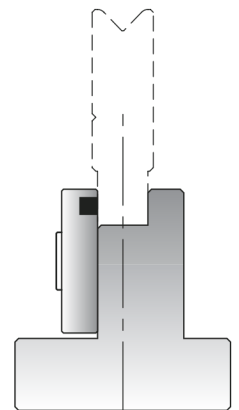
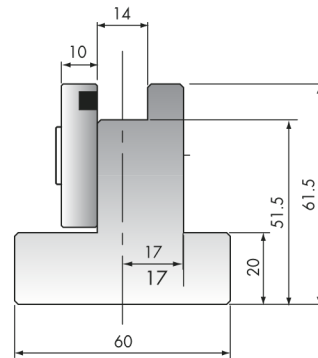

	max t/m
SU61F	100
SU61F/C	100

PROMECAM-AMADA TYPE

RKS-01-M26-90-01-835

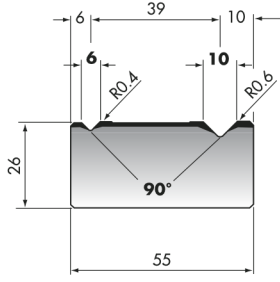

max t/m

26-90-01 100

RKS-01-M26-90-02-835

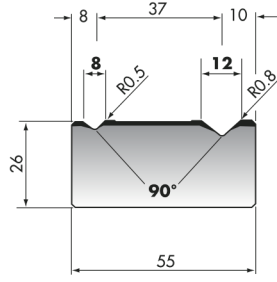

max t/m

26-90-02 100

RKS-01-M26-88-01-835

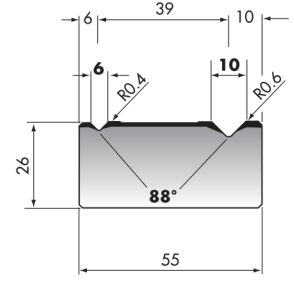

max t/m

26-88-01 100

RKS-01-M26-88-02-835

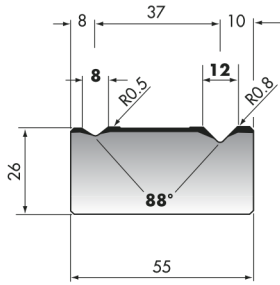

max t/m

26-88-02 100

RKS-01-M26-88-03-835

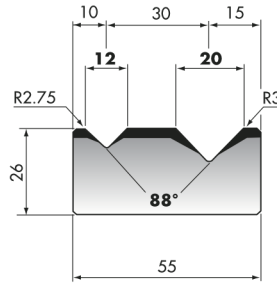

max t/m

26-88-03 100

RKS-01-M26-88-04-835

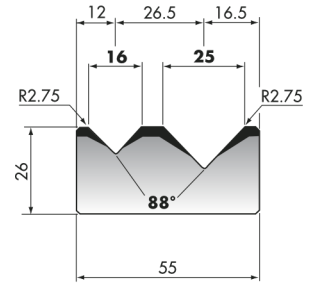

max t/m

26-88-04 100

RKS-01-M26-88-05-835

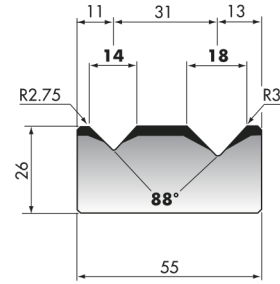

max t/m

26-88-05 100

RKS-01-M26-60-01-835

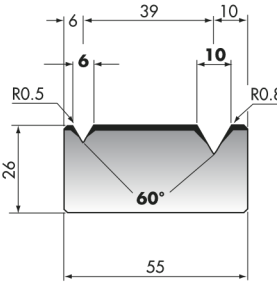

max t/m

26-60-01 60

RKS-01-M26-60-02-835

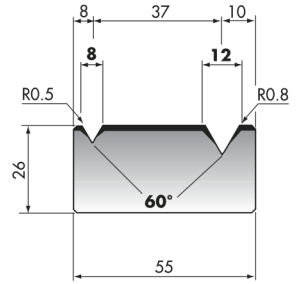

max t/m

26-60-02 80

RKS-01-M26-60-03-835

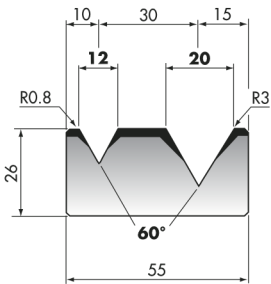

max t/m

26-60-03 80

RKS-01-M26-60-05-835

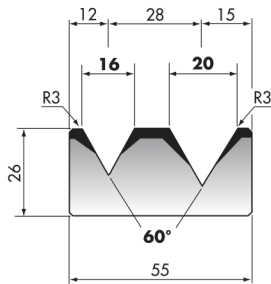

max t/m

26-60-05 80

RKS-01-M31-35-01-835

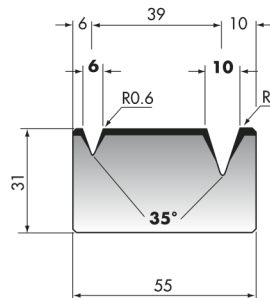

max t/m

31-35-01 30

RKS-01-M31-35-02-835

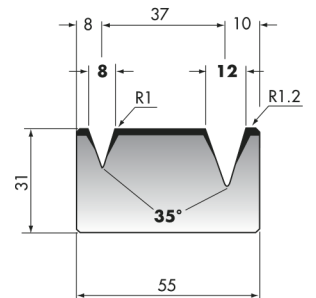

max t/m

31-35-02 30

PROMECAM-AMADA TYPE

RKS-01-SU034-830

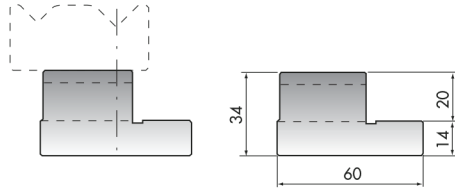

34

RKS-01-SU055-830

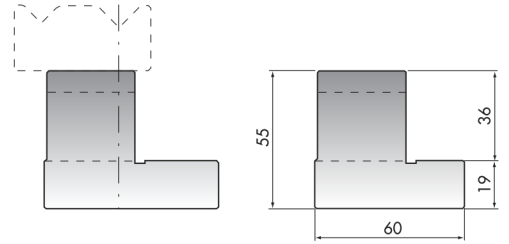

55

RKS-01-SU075-830

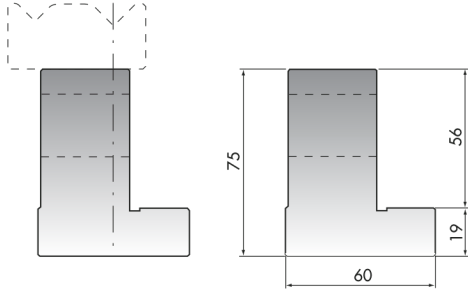

75

RKS-01-MPG25-835

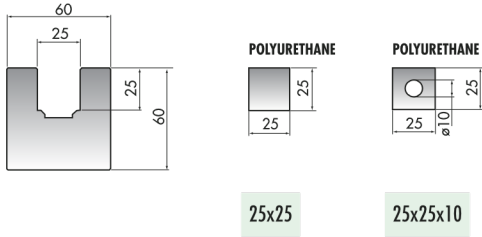

25

25x25

25x25x10

RKS-01-MPG50-835

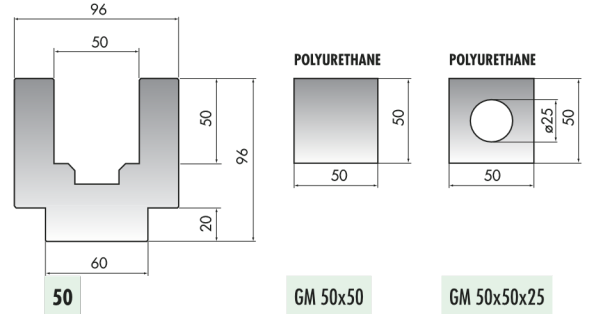

50

GM 50x50

GM 50x50x25

RKS-01-MPG75-835

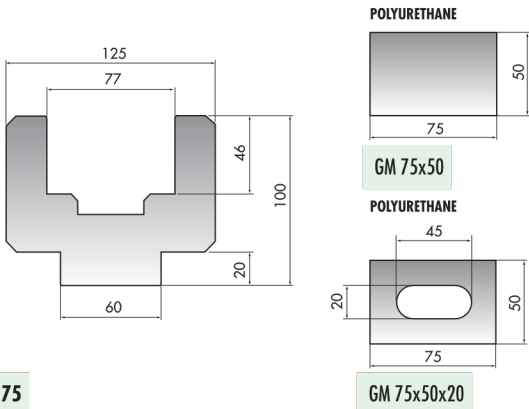

75

GM 75x50x20

RKS-01-MPG100-835

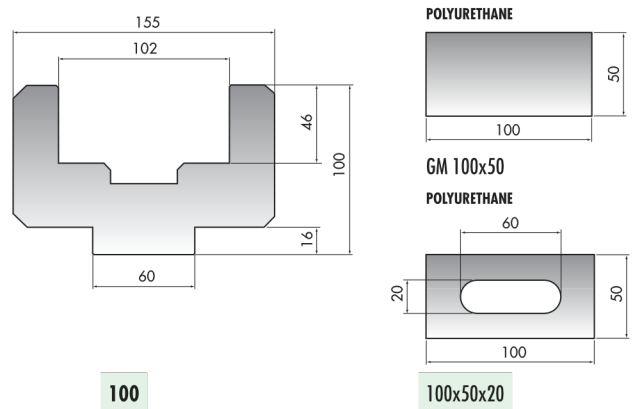

100

GM 100x50x20

RKS-01-PSTCON

	A	B
25	(2) 58	58
50	(2) 108	75
75	(2) 123	80
100	(2) 153	80

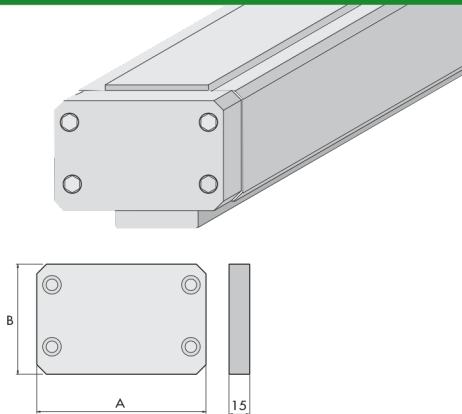

PROMECAM-AMADA TYPE

RKS-01-46-10-90-835

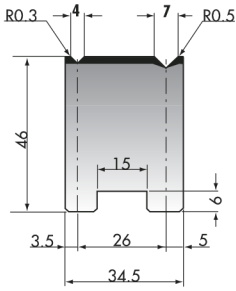

max t/m
01-46-10 80

RKS-01-46-11-90-835

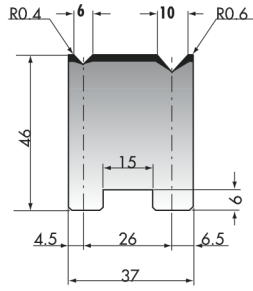

max t/m
01-46-11 80

RKS-01-46-12-90-835

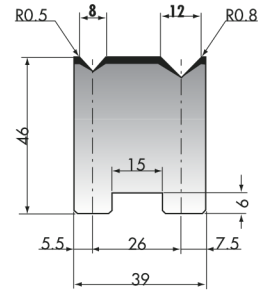

max t/m
01-46-12 80

RKS-01-46-13-88-835

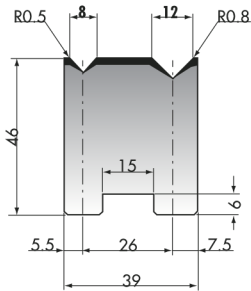

max t/m
01-46-13 80

RKS-01-46-14-88-835

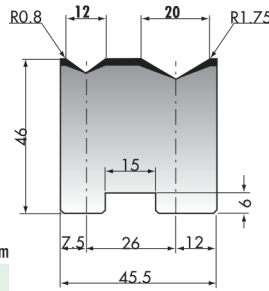

max t/m
01-46-14 80

RKS-01-46-15-88-835

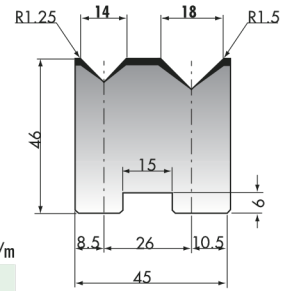

max t/m
01-46-15 80

RKS-01-46-16-88-835

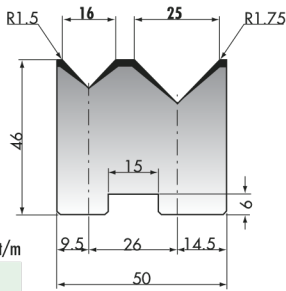

max t/m
01-46-16 80

RKS-01-46-17-30-835

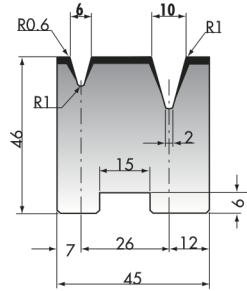

max t/m
01-46-17 40

RKS-01-46-18-30-835

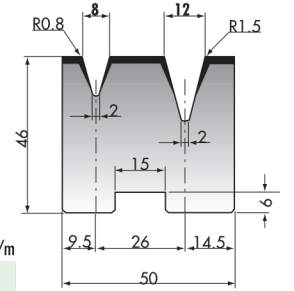

max t/m
01-46-18 40

RKS-01-PM50-835

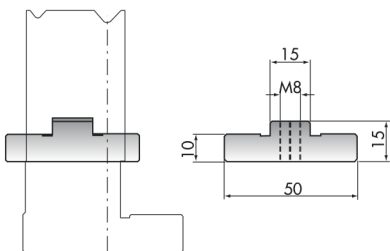

01-50

RKS-01-PM60-835

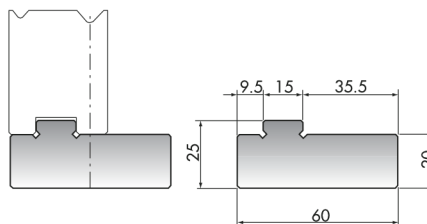

01-60

RKS-01-PB60

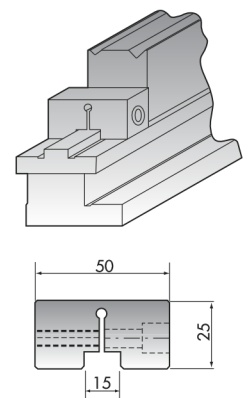

01-60 (2)

PROMECAM-AMADA TYPE

RKS-01 (P+M)-28-525

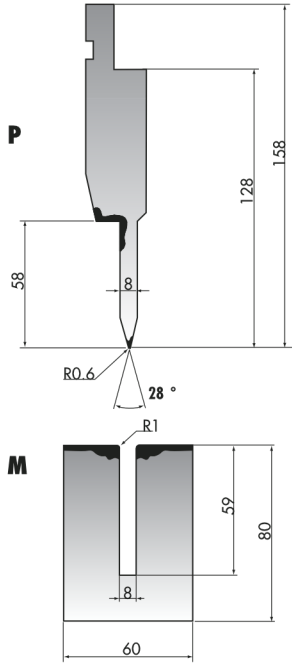

max t/m

RKS-01-134.28.8	A	B
P-134.28.8	80	100
M-134.28.8	50	100

RKS-01 (P+M)-24-525

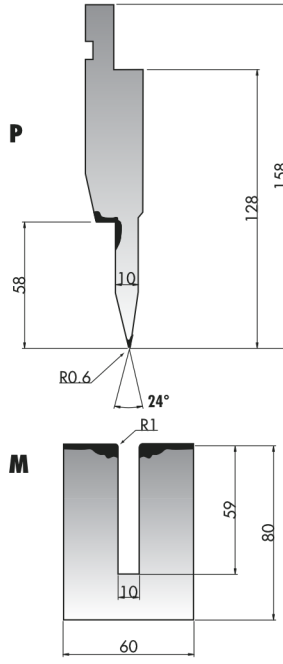

max t/m

RKS-01-134.24.10	A	B
P-134.24.10	80	100
M-134.24.10	50	100

RKS-01 (P+M)-24-525

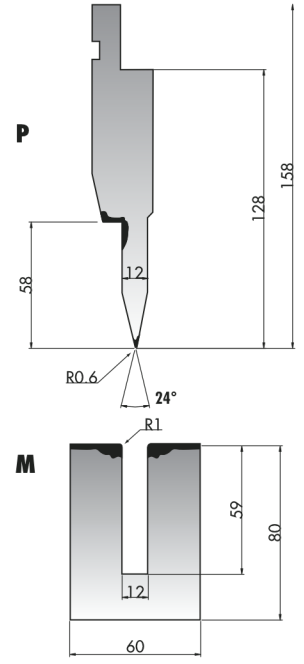

max t/m

RKS-01-134.24.12	A	B
P-134.24.12	80	100
M-134.24.12	50	100

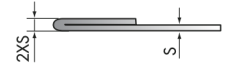
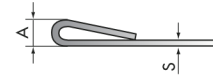
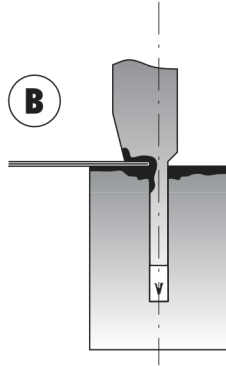
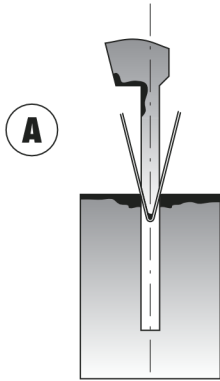

S	A	R.45 Kg/mm ²	R.70 Kg/mm ²
mm	mm	t/m	t/m
0,6	3,0	9	15
0,8	3,0	12	20
1,0	3,5	15	25
1,25	3,5	17	26
1,5	4,6	22	38
2,0	5,5	30	50

S	A	R.45 Kg/mm ²	R.70 Kg/mm ²
mm	mm	t/m	t/m
0,6	1,2	23	35
0,8	1,6	32	50
1,0	2,0	40	60
1,25	2,5	50	80
1,5	3,0	63	95
2,0	4,0	80	130

RKS-01-134.28.8/F
P-134.28.8/F
M-134.28.8/F

RKS-01-134.24.10/F
P-134.24.10/F
M-134.24.10/F

RKS-01-134.24.12/F
P-134.24.12/F
M-134.24.12/F

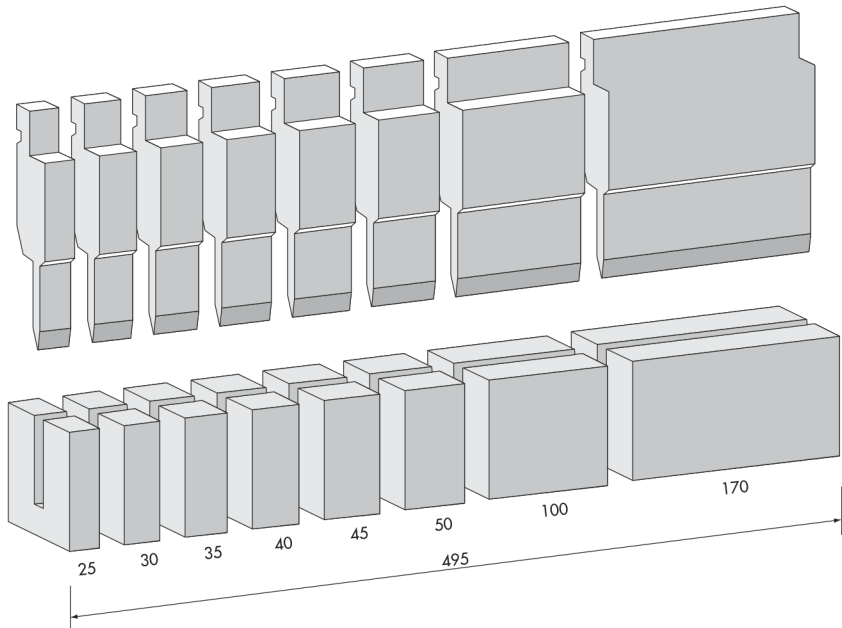

PROMECAM-AMADA TYPE

RKS-01-S101-35-06-835

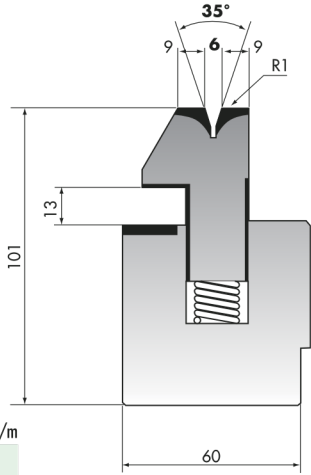

max t/m
35-06 60

RKS-01-S101-35-08-835

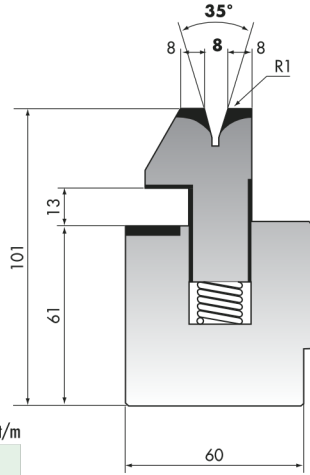

max t/m
35-08 60

RKS-01-S101-35-10-835

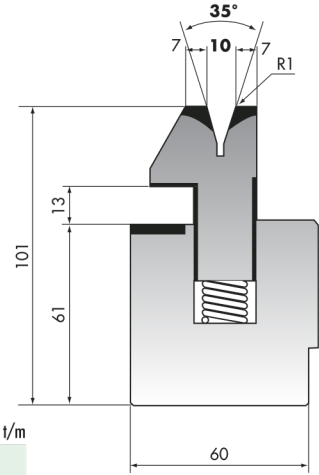

max t/m
35-10 60

RKS-01-S110-30-08-835

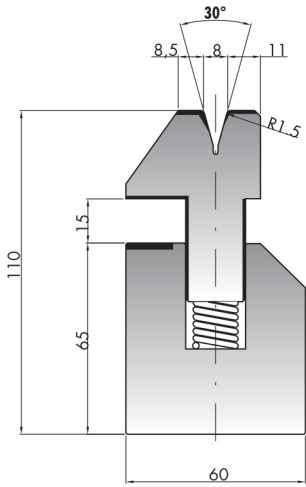

max t/m
30-08 80

RKS-01-S135-26-08-835

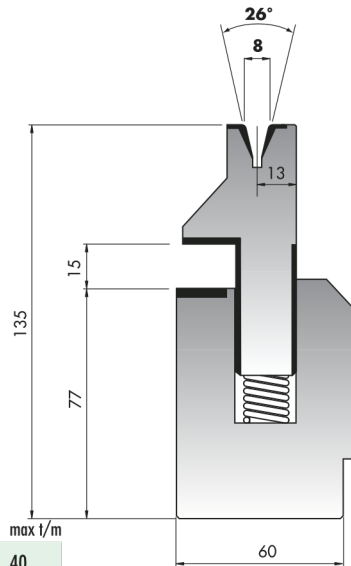

max t/m
26-08 40

RKS-01-S135-26-10-835

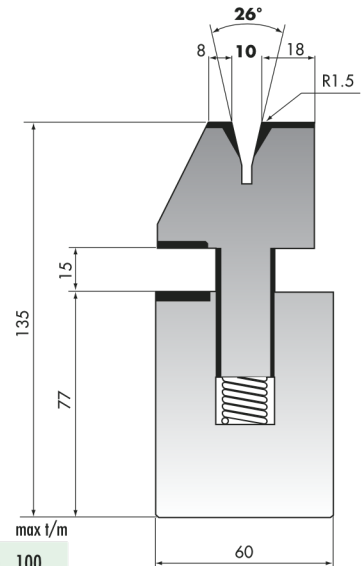

max t/m
26-10 100

RKS-01-SA135-26-12-835

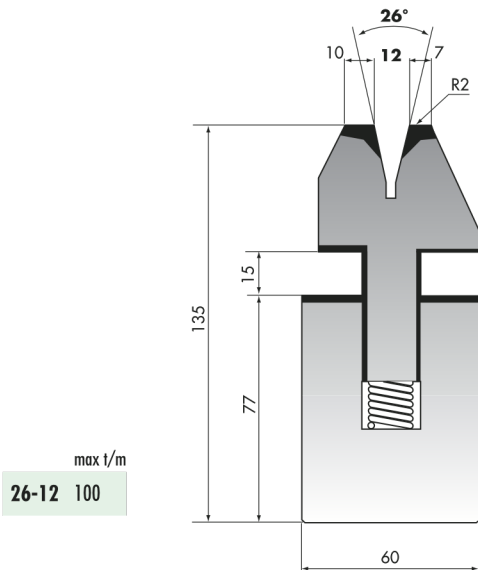

max t/m
26-12 100

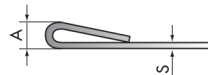

S	A	R.45 Kgf/mm ²	R.70 Kgf/mm ²
mm	mm	t/m	t/m
0,6	3,0	9	15
0,8	3,0	12	20
1,0	3,5	15	25
1,25	3,5	17	26
1,5	4,6	22	38
2,0	5,5	30	50
2,5	6,5	55	
3,0	8,0	70	



S	A	R.45 Kgf/mm ²	R.70 Kgf/mm ²
mm	mm	t/m	t/m
0,6	1,2	23	35
0,8	1,6	32	50
1,0	2,0	40	60
1,25	2,5	50	80
1,5	3,0	63	95
2,0	4,0	80	130
2,5	5,0	90	
3,0	6,0	100	

PROMECAM-AMADA TYPE

RKS-01-CPZ-835

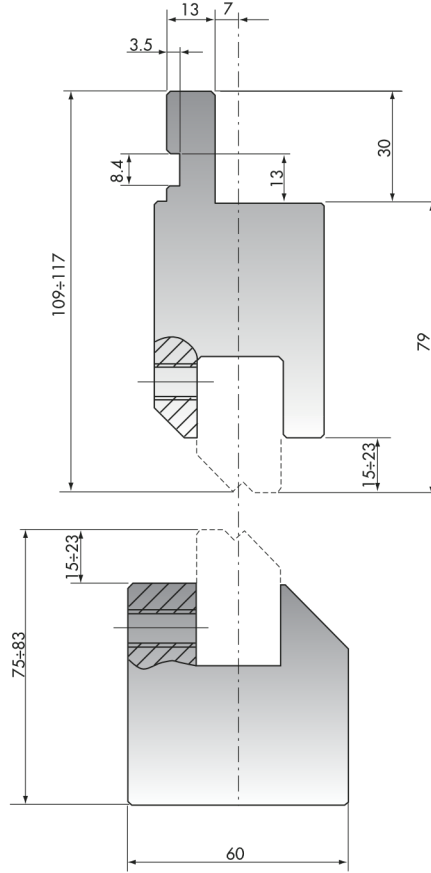

max t/m
RKS-01-CPZ 100

RKS-01-CEZ(1-1,5-2-2,5-3-3,5-4-4,5-5-5,5-6-6,5-7-7,5-8-9-10-11-12-13-14-15)-90-140-150-160-835

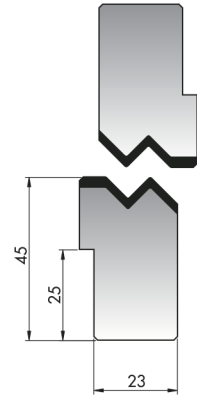
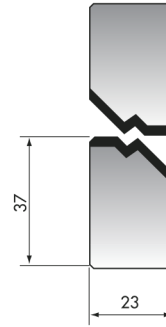
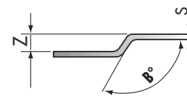
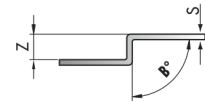
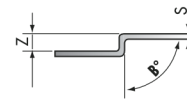

	Z mm	B°	S* mm	max t/m
1	1	160°	1,2	100
1.5	1,5	160°	1,5	100
2	2	150°	1,4	100
2.5	2,5	140°	1,3	100
3	3	90°	1	100
3.5	3,5	90°	1	100
4	4	90°	1,2	100
4.5	4,5	90°	1,2	100
5	5	90°	1,3	100
5,5	5,5	90°	1,4	100
6	6	90°	1,5	100
6.5	6,5	90°	1,5	100
7	7	90°	1,5	100
7.5	7,5	90°	1,6	100
8	8	90°	1,6	100

* Fe Rmax=42 kg/mm²

	Z mm	B°	S* mm	max t/m
9	9	90°	1,8	100
10	10	90°	1,8	100
11	11	90°	2	100
12	12	90°	2	100
13	13	90°	2	100
14	14	90°	2	100
15	15	90°	2,3	100

* Fe Rmax=42 kg/mm²

PROMECAM-AMADA TYPE

RKS-01-C 2000/S C 2500/S C 3000/S C 4000/S

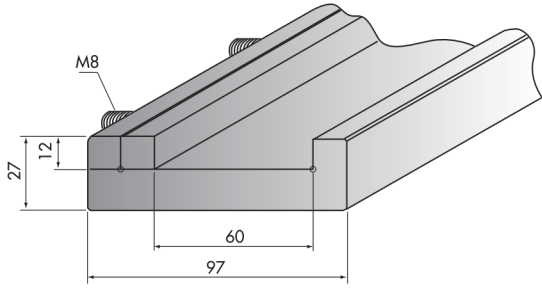

mm	
2000	2100
2500	2600
3000	3100
4000	4100

RKS-01-C 1050/R-520

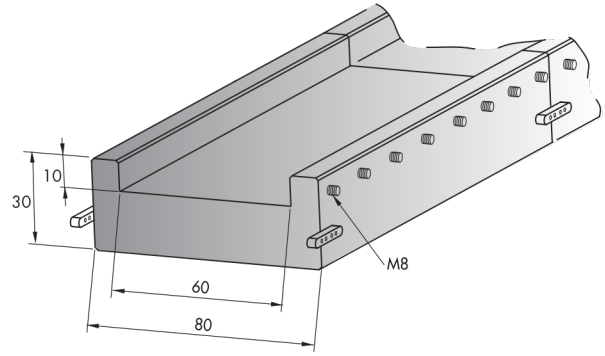

mm	
1050	1050
1050	520

RKS-01-C 1050/RS-520

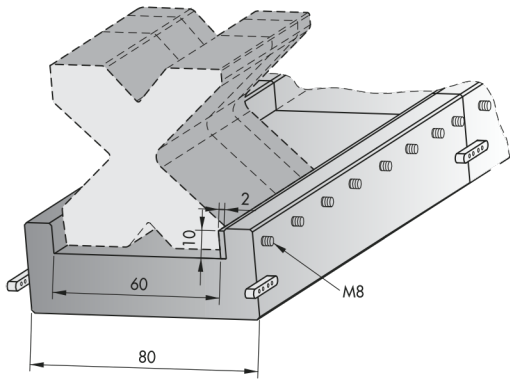

mm	
1050	1050
1050	520

RKS-01C 1050-90-520

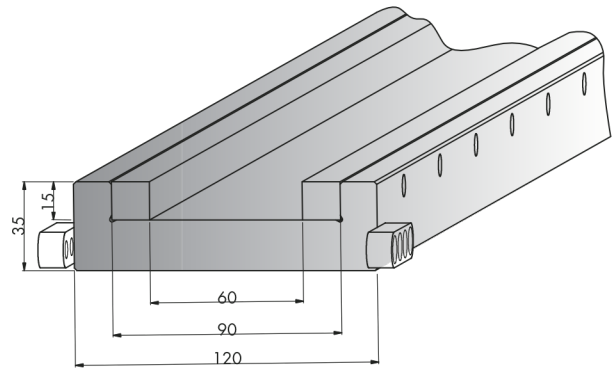

mm	
1050-90	1050
1050-90	520

RKS-01-INT100

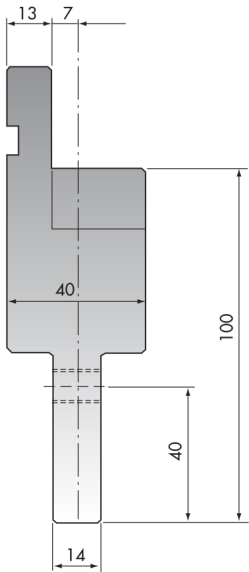

max t/m	
100	100

RKS-01-INT120

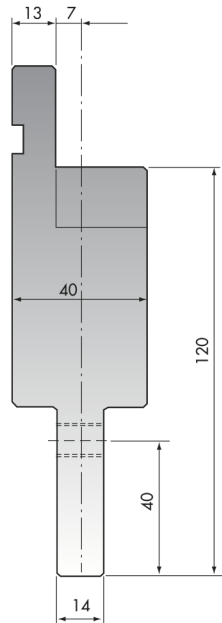

max t/m	
120	100

RKS-01-INT120-40

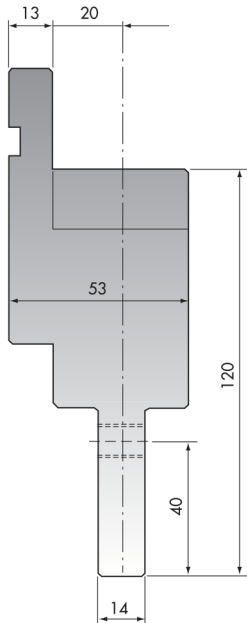

max t/m	
120-40	100

RKS-01-INT100 FISSO

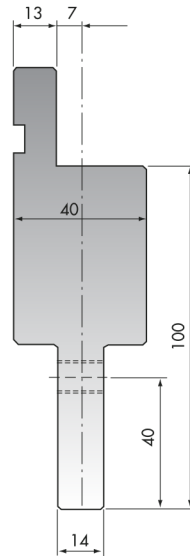

max t/m	
100 FISSO	100

RKS-01-INT150

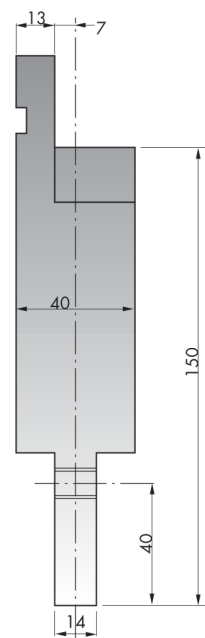

max t/m	
150	100

PROMECAM-AMADA TYPE

RKS-01-ST50 RKS-01-ST50R RKS-01-STG50-150

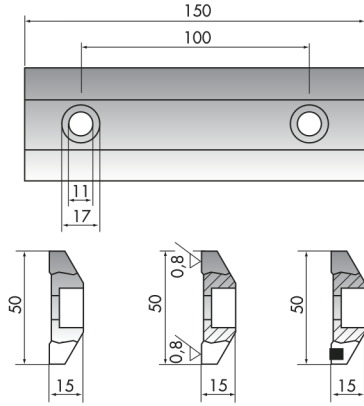

RKS-01-ST60 RKS-01-ST60R RKS-01-STG60-150

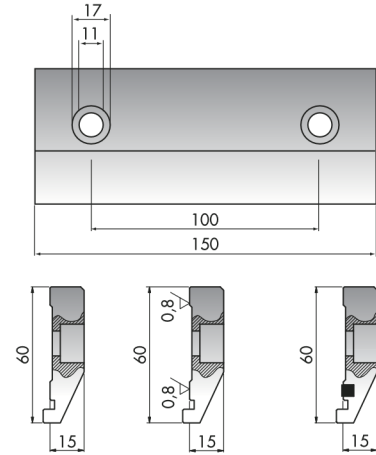

RKS-01-STL60 RKS-01-STL60R RKS-01-STLG60-150

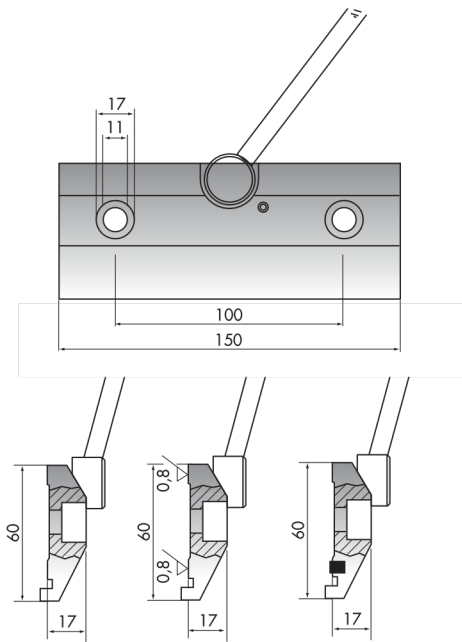

RKS-01-STX60 RKS-01-STX60R RKS-01-STXG60-150

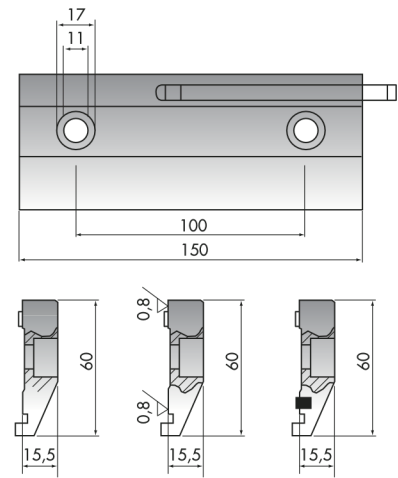

RKS-01-KDS

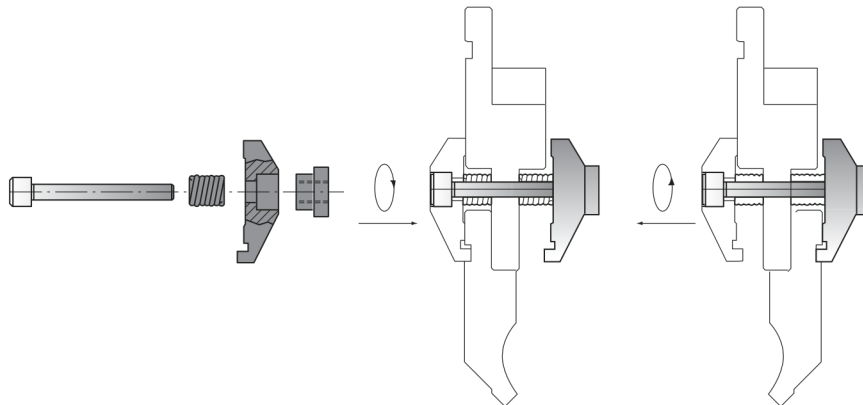

PROMECAM-AMADA TYPE

RKS-01-STANDARD

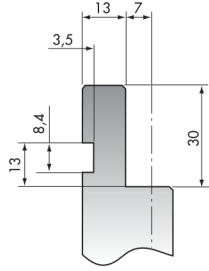

RKS-01-ADX-150

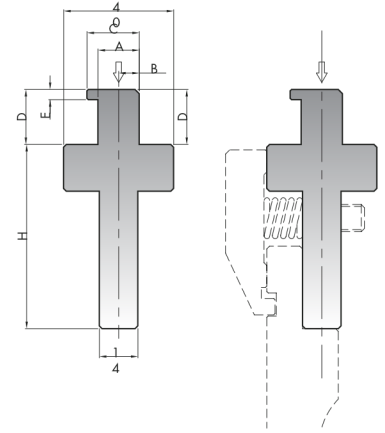

RKS-01-AD4-150

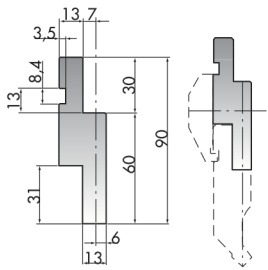

max l/m

4 100

RKS-01-A1

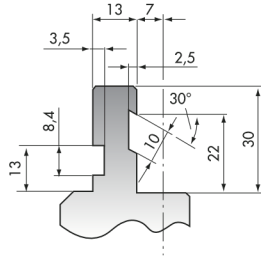

1

RKS-01-A6

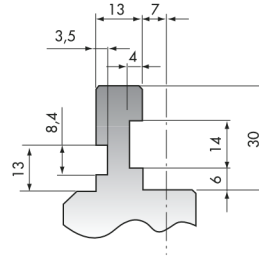

6

RKS-01-A7

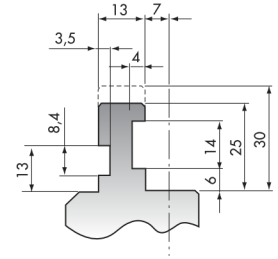

7

RKS-01-A8

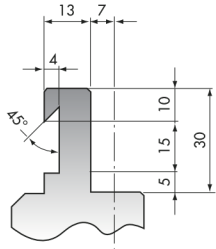

8

RKS-01-A9

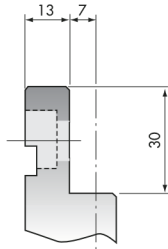

9

RKS-01-A41

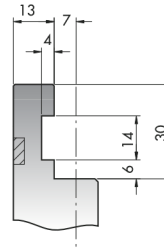

41

RKS-01-A42

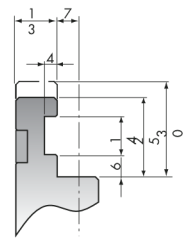

42

RKS-01-CTS60-835-415

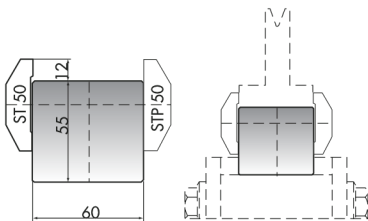

mm

835
415

RKS-01-02-03-AD5-1000-500

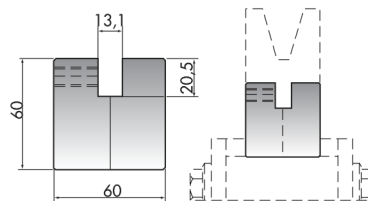

mm

1000
500

RKS-01-02-03-AD6-1000-500

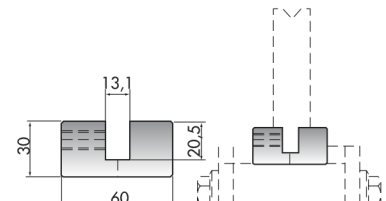

mm

1000
500

TRUMPF-WILA TYPE

RKS-02-TPR256-86-R1-500

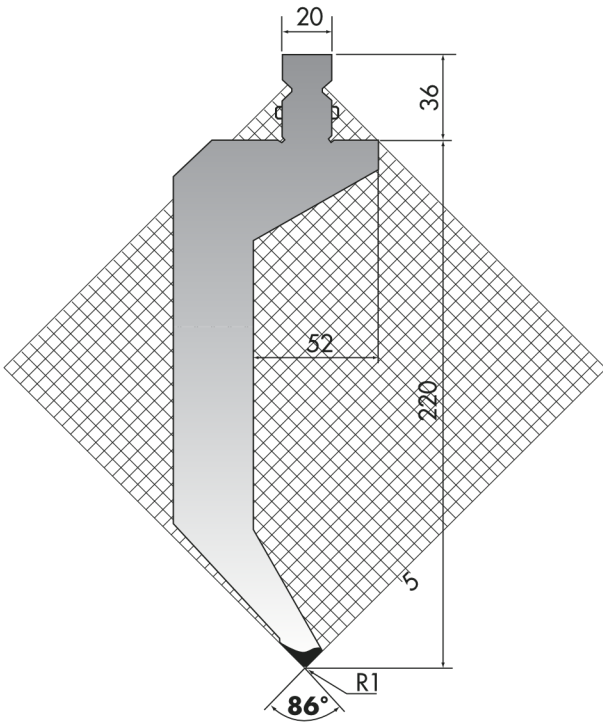

max t/m
86-R1 80

RKS-02-TPR256-86-R1-A-500

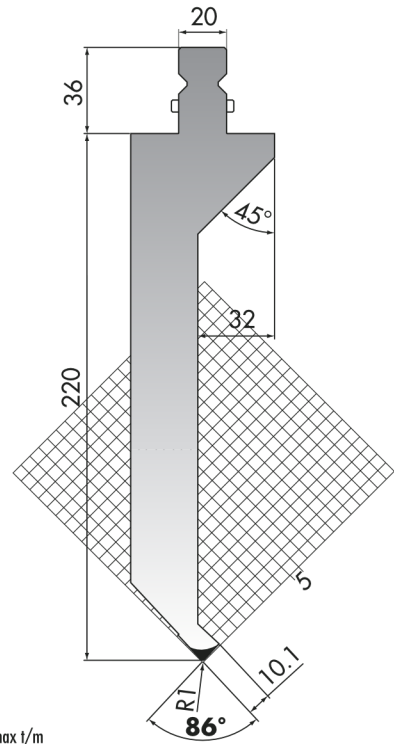

max t/m
86-R1-A 80

RKS-02-TPR157-86-R1-500

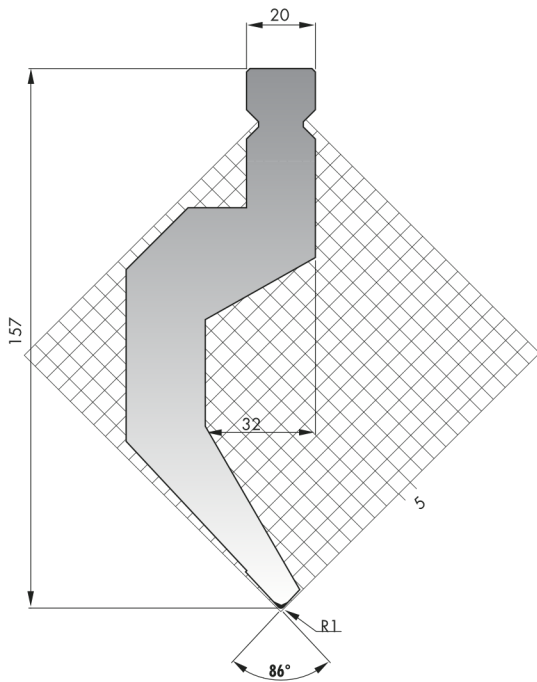

max t/m
86-R1 80

RKS-02-TPR157-86-R1-A-500

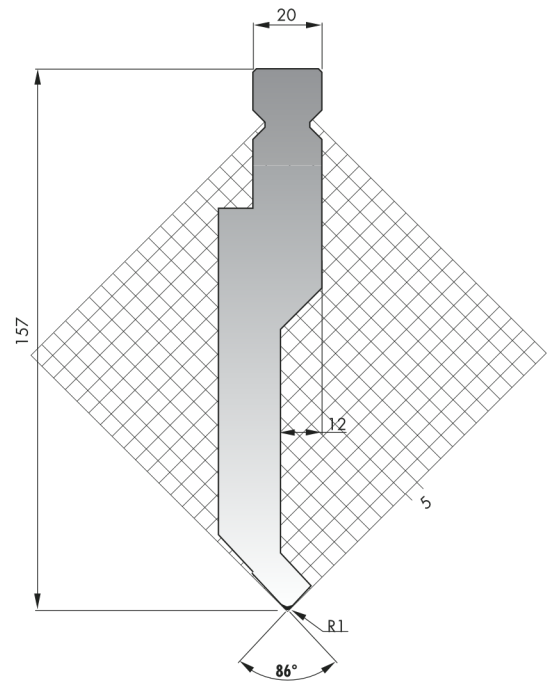

max t/m
86-R1-A 80

TRUMPF-WILA TYPE

RKS-02-TPR256-60-R4-500

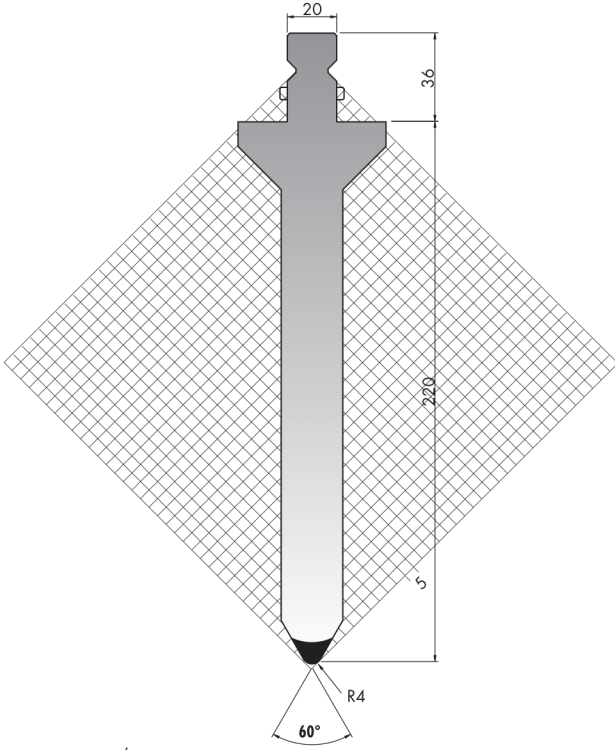

max t/m

60-R4 130

RKS-02-TPR157-60-R4-500

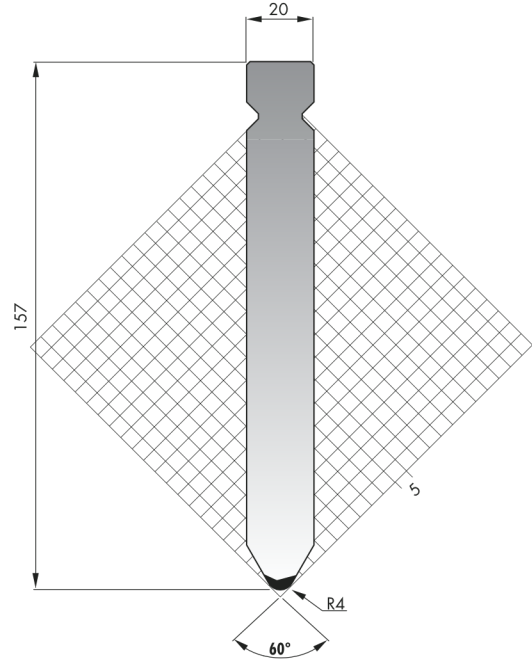

max t/m

60-R4 130

RKS-02-TPR256-28-R1-500

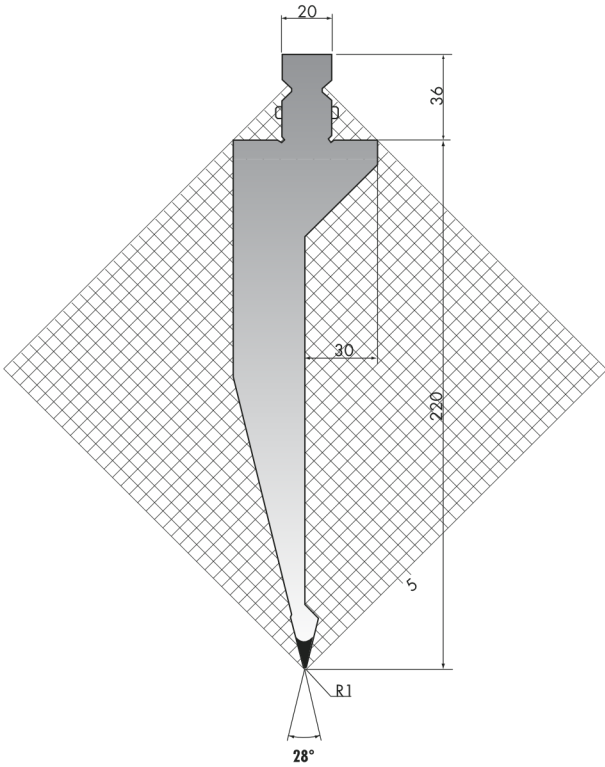

max t/m

28-R1 60

RKS-02-TPR276-28-R1-500

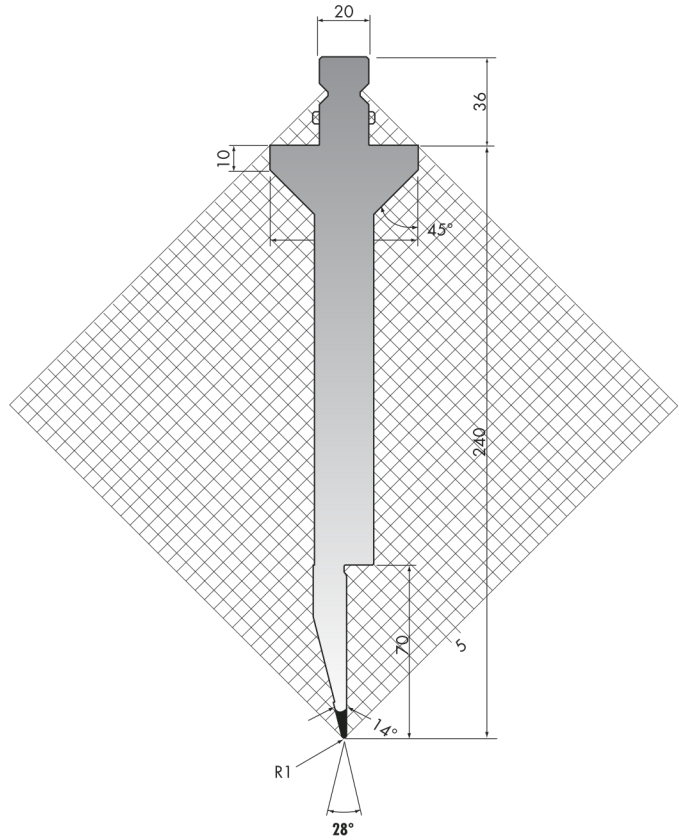

max t/m

28-R1 40

TRUMPF-WILA TYPE

RKS-02-TPR176-28-R1-500

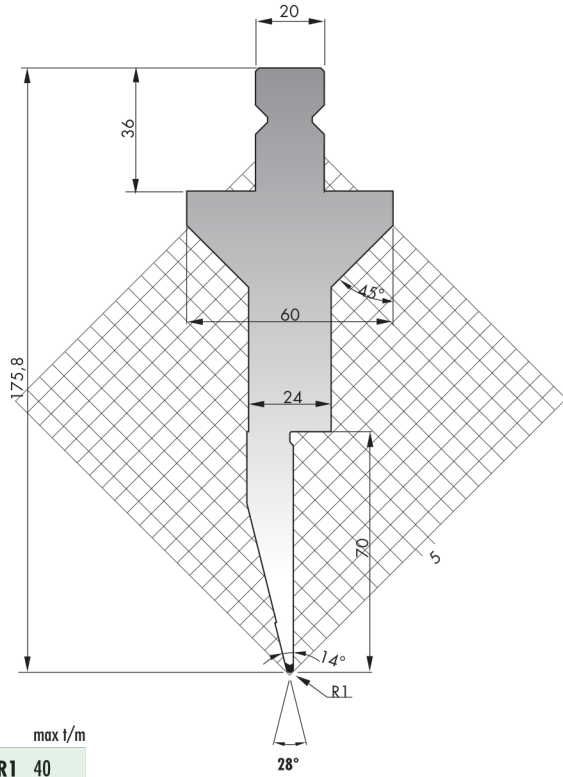

max t/m
28-R1 40

RKS-02-TPR157-28-R1-500

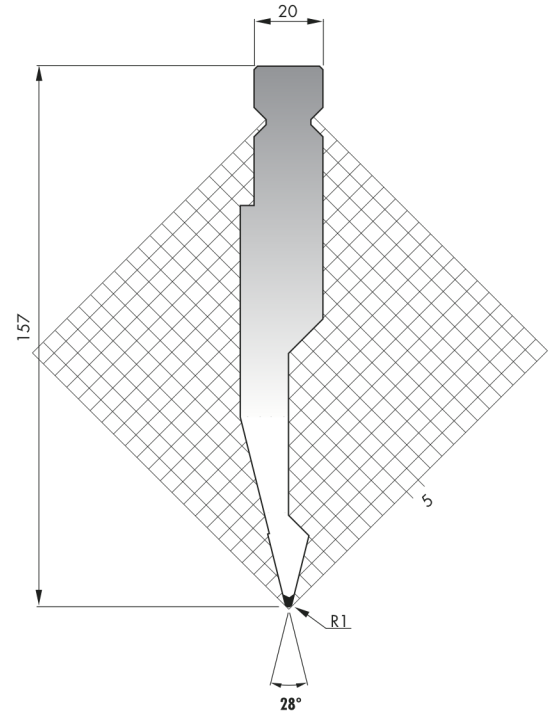

max t/m
28-R1 60

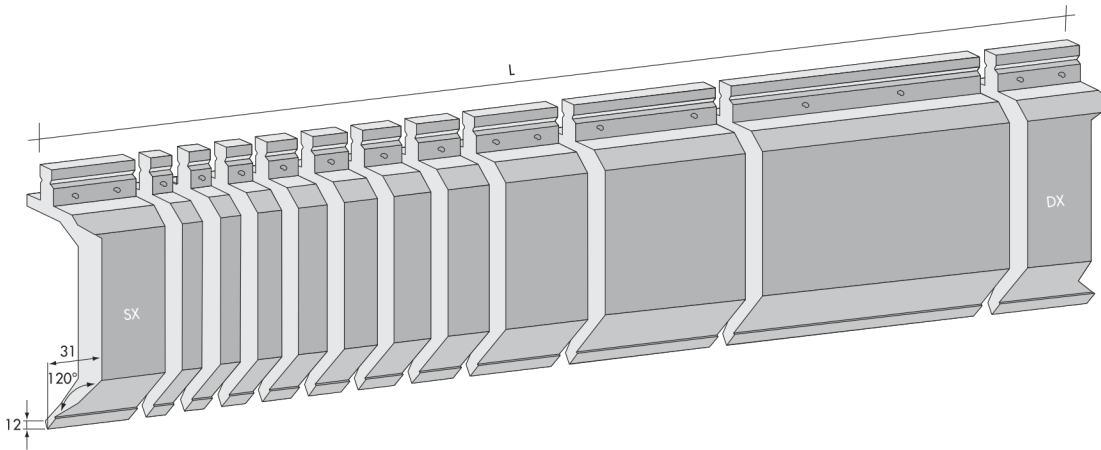

RKS-02-TPR2...6/FD/(L)

- L
- 300
- 200
- 100
- 100
- DX100
- SX50
- 45
- 40
- 35
- 30
- 25

RKS-02-TPR2...6/FA/(L)

L	25	30	35	40	45	50	100 DX	100 SX	100
1250	2	1	1	1	1	1	1	1	8
2050	2	1	1	1	1	1	1	1	16
2550	2	1	1	1	1	1	1	1	21
3050	2	1	1	1	1	1	1	1	26
4050	2	1	1	1	1	1	1	1	36

RKS-02-TPR2...6/FB/(L)

L	25	30	35	40	45	50	100 DX	100 SX	100	200	300
1250	2	1	1	1	1	1	1	1	1	2	1
2050	2	1	1	1	1	1	1	1	1	3	3
2550	2	1	1	1	1	1	1	1	1	4	4
3050	2	1	1	1	1	1	1	1	1	5	5
4050	2	1	1	1	1	1	1	1	1	7	7

RKS-02-TPR2...6/FC/(L)

L	25	30	35	40	45	50
250	2	1	1	1	1	1

TRUMPF-WILA TYPE

RKS-02-TMR100-(06...50)-86-500

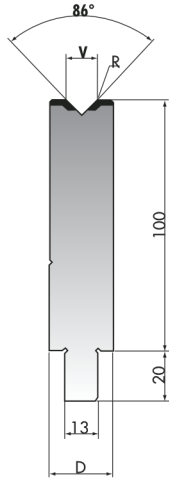

	V	R	D	max t/m
06-86	6	0,6	20	120
08-86	8	0,8	20	115
10-86	10	1	20	110
12-86	12	1	25	120
16-86	16	1,6	30	120
20-86	20	2	30	115
24-86	24	2,5	35	120
30-86	30	3	45	120
40-86	40	3	55	120
50-86	50	3	75	150

RKS-02-TMR100-TMR120-(60...100)-80-500

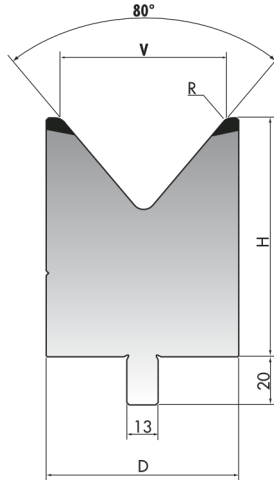

	V	H	R	D	max t/m
60-80	60	100	5	75	150
70-80	70	100	5	85	150
80-80	80	100	5	100	150
90-80	90	120	8	110	150
100-80	100	120	8	120	150

RKS-02-TMR100-(06...30)-30-500

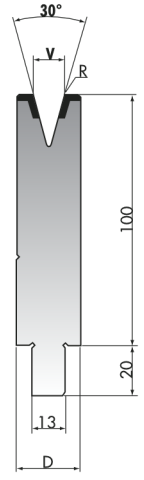

	V	R	D	max t/m
06-30	6	0,6	20	40
08-30	8	1	20	40
10-30	10	1	20	40
12-30	12	1	25	40
16-30	16	1,6	30	50
20-30	20	2	35	60
24-30	24	2,5	40	65
30-30	30	3	55	90

RKS-02-TMR

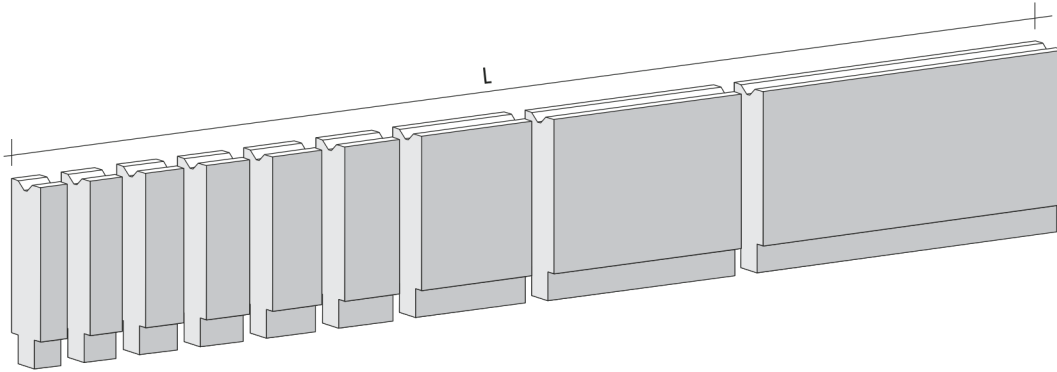

RKS-02-TMR1...0/FA/(L)

L	25	30	35	40	45	50	100
1250	2	1	1	1	1	1	10
2050	2	1	1	1	1	1	18
2550	2	1	1	1	1	1	23
3050	2	1	1	1	1	1	28
4050	2	1	1	1	1	1	38

RKS-02-TMR1...0/FC/(L)

L	25	30	35	40	45	50
250	2	1	1	1	1	1

RKS-02-TMR1...0/FD/(L)

300
200
100
50
45
40
35
30
25

RKS-02-TMR1...0/FB/(L)

L	25	30	35	40	45	50	100	200	300	500
1250	2	1	1	1	1	1	3	2	1	0
2050	2	1	1	1	1	1	3	1	1	2
2550	2	1	1	1	1	1	3	1	1	3
3050	2	1	1	1	1	1	3	1	1	4
4050	2	1	1	1	1	1	3	1	1	6

TRUMPF-WILA TYPE

RKS-02-TMI100



max t/m
100 130

RKS-02-TML100

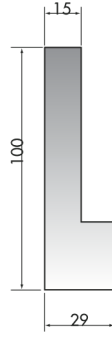

max t/m
100 120

RKS-02-TMS100

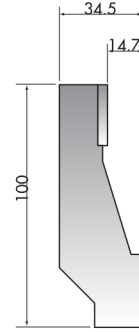

max t/m
100 130

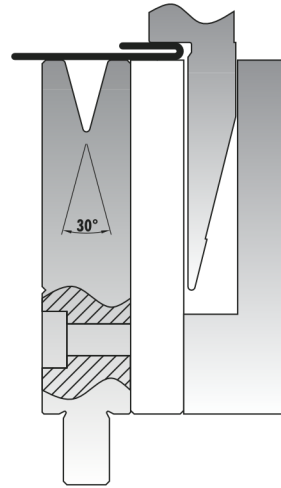
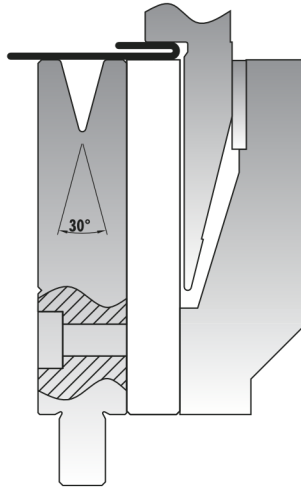

RKS-02-01-AD11-150

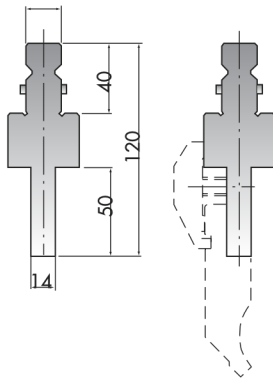

max t/m
11 100

RKS-02-03-01-AD7-835-415

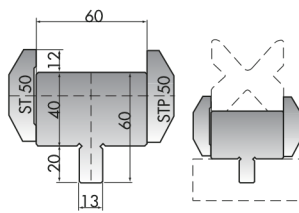

max t/m
7 835
7/C 415

RKS-02-03-01-A30-835-415-805

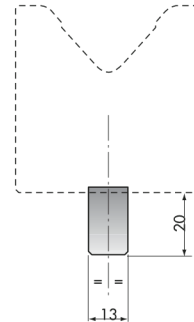

max t/m
30 835
30/C 415
30/F 805

RKS-02-AD21-150

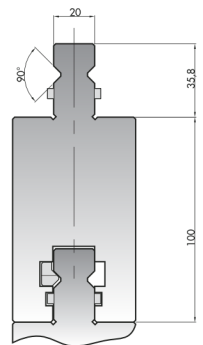

max t/m
21 150

TRUMPF-WILA TYPE

RKS-02(P+M)-28-525

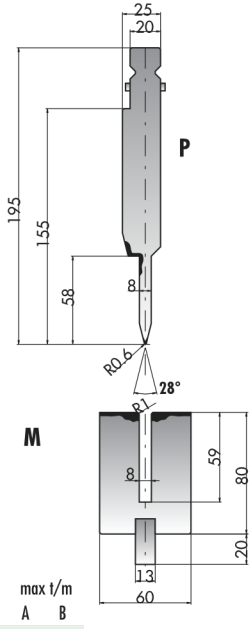

195.28.8		
195.28.8	80	100
195.28.8	50	100

RKS-02-(P+M)-24-525

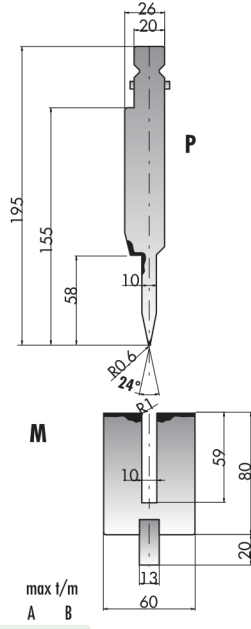

195.24.10		
195.24.10	80	100
195.24.10	50	100

RKS-02--(P+M)-24-525

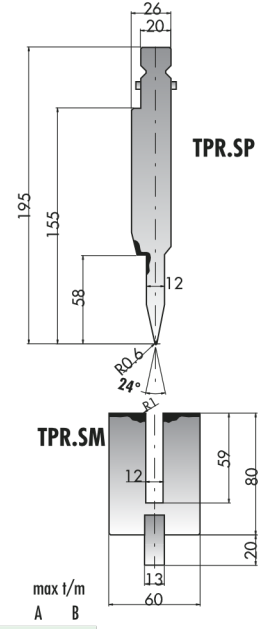

195.24.12		
195.24.12	80	100
195.24.12	50	100

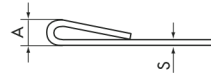
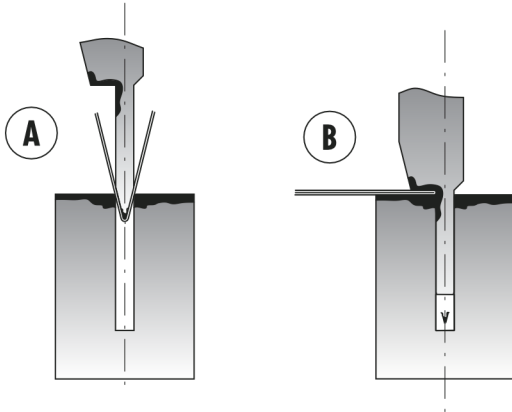

S	A	R.45 Kgf/mm ²	R.70 Kgf/mm ²
mm	mm	t/m	t/m
0,6	3,0	9	15
0,8	3,0	12	20
1,0	3,5	15	25
1,25	3,5	17	26
1,5	4,6	22	38
2,0	5,5	30	50

S	A	R.45 Kgf/mm ²	R.70 Kgf/mm ²
mm	mm	t/m	t/m
0,6	1,2	23	35
0,8	1,6	32	50
1,0	2,0	40	60
1,25	2,5	50	80
1,5	3,0	63	95
2,0	4,0	80	130

195.28.8/F
195.28.8/F
195.28.8/F

195.24.10/F
195.24.10/F
195.24.10/F

195.24.12/F
195.24.12/F
195.24.12/F

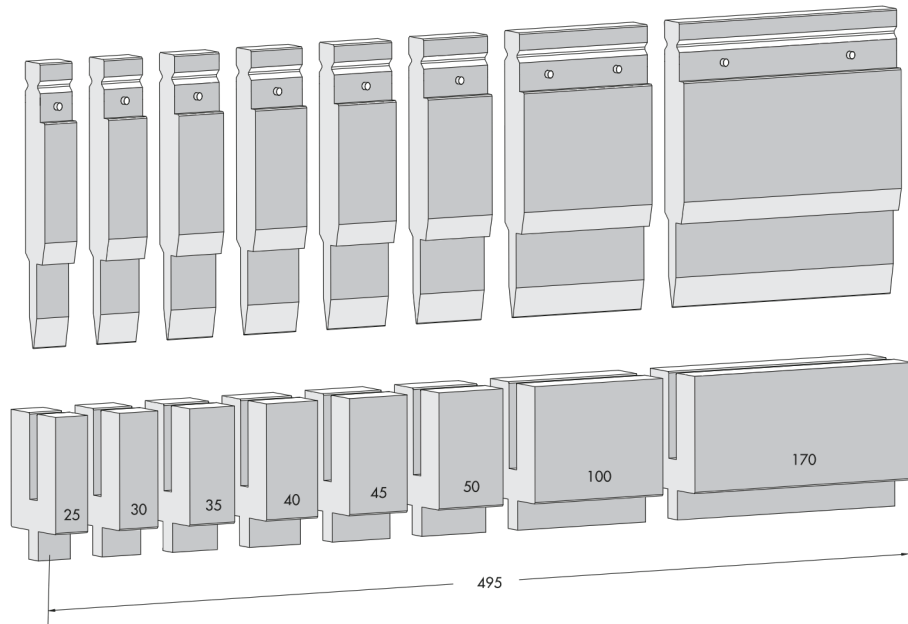

TRUMPF-WILA TYPE

RKS-02-TPR143.10-522

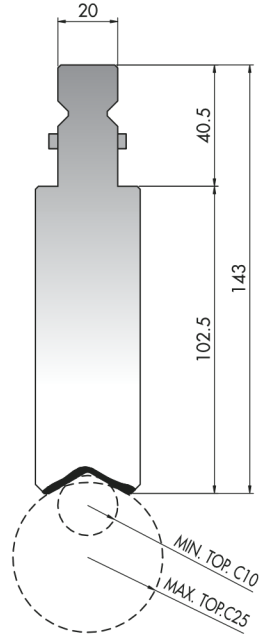

max t/m
143.10 100

RKS-02-TPR136.15-522

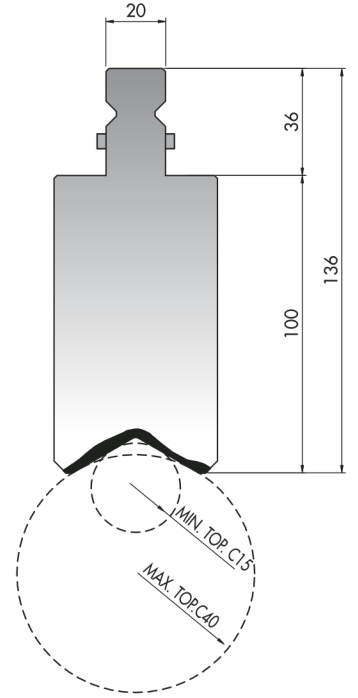

max t/m
136.15 100

RKS-02-TPR

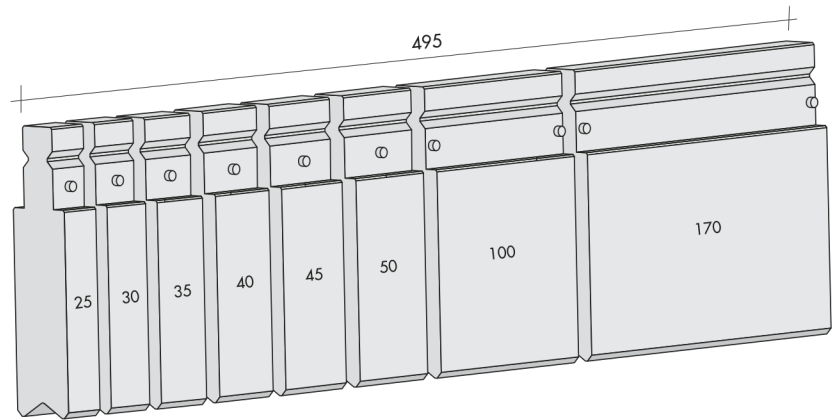

RKS-02-C-(10-40)-525

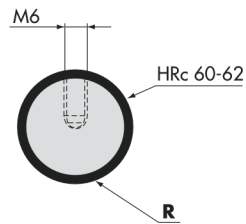

R mm	max t/m
10	10 100
12.5	12,5 100
15	15 100
17.5	17,5 100

R mm	max t/m
20	20 100
25	25 100
30	30 100
35	35 100
40	40 100

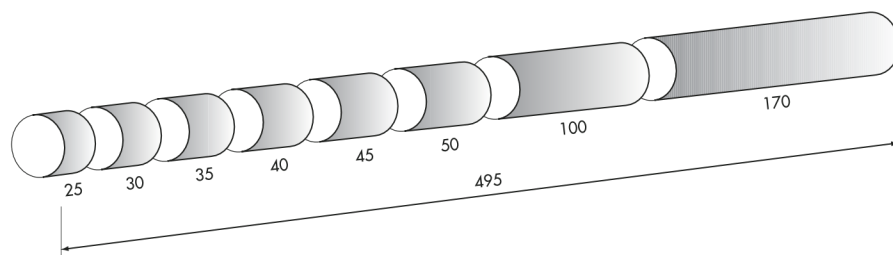

TRUMPF-WILA TYPE

RKS-02-TPZ-835-415

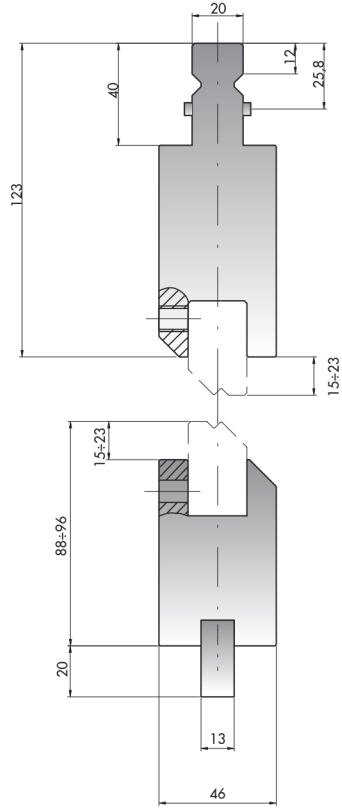

	mm	max t/m
RKS-02-TPZ	835	100
RKS-02-TPZ/C	415	100

RKS-02-CEZ-(1-1.5-2-2.5-3-3.5-4-4.5-5-5.5-6-6.5-7--7.5-8-9-10-11-12-13-14-15)-90-140-150-160)-835-415



	Z mm	B°	S* mm	max t/m
1	1	160°	1,2	100
1.5	1,5	160°	1,5	100
2	2	150°	1,4	100
2.5	2,5	140°	1,3	100
3	3	90°	1	100
3.5	3,5	90°	1	100
4	4	90°	1,2	100
4.5	4,5	90°	1,2	100
5	5	90°	1,3	100
5.5	5,5	90°	1,4	100
6	6	90°	1,5	100
6.5	6,5	90°	1,5	100
7	7	90°	1,5	100
7.5	7,5	90°	1,6	100
8	8	90°	1,6	100

* Fe Rmax=42 kg/mm²



	Z mm	B°	S* mm	max t/m
9	9	90°	1,8	100
10	10	90°	1,8	100
11	11	90°	2	100
12	12	90°	2	100
13	13	90°	2	100
14	14	90°	2	100
15	15	90°	2,3	100

* Fe Rmax=42 kg/mm²

BEYELER TYPE

RKS-03-BPR250-P4-RFA-508

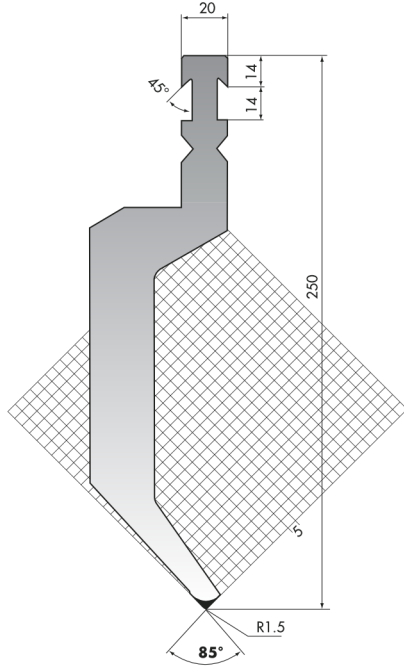

max t/m
P4-RFA 90

RKS-03-BPR250-P5-RFA-508

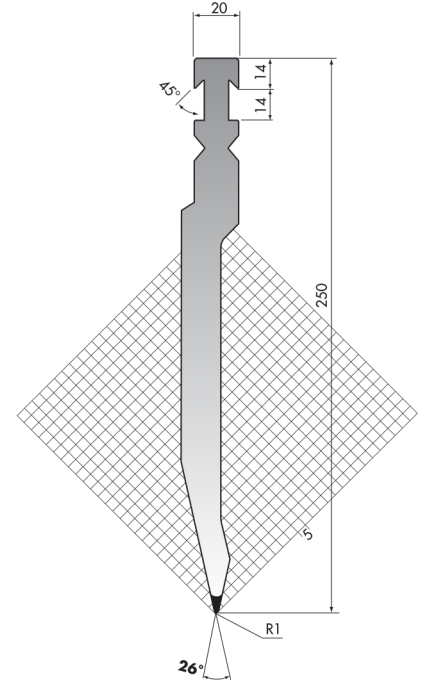

max t/m
P5-RFA 100

RKS-03-BPR250-P4-RF-508

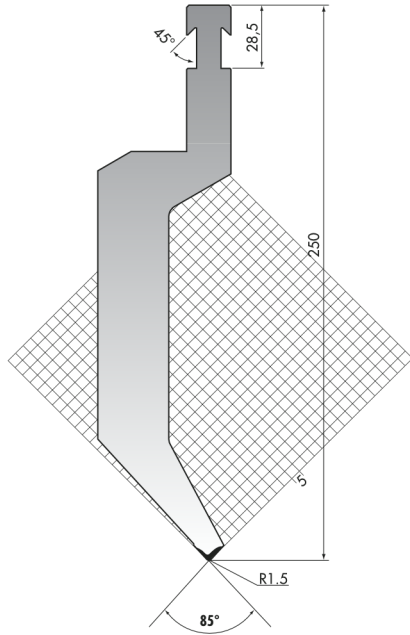

max t/m
P4-RF 90

RKS-03-BPR250-P5-RF

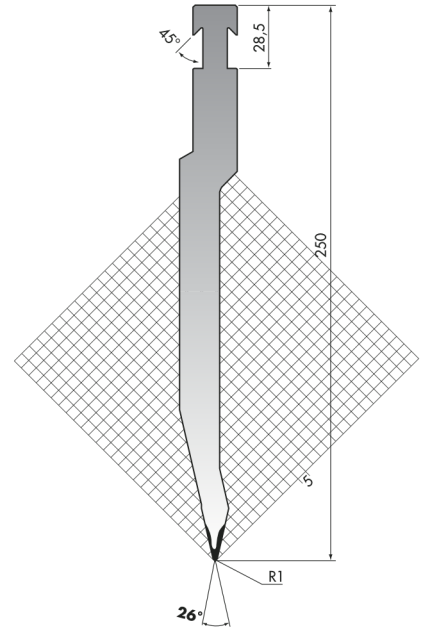

max t/m
P5-RF 100

RKS-03-BPR

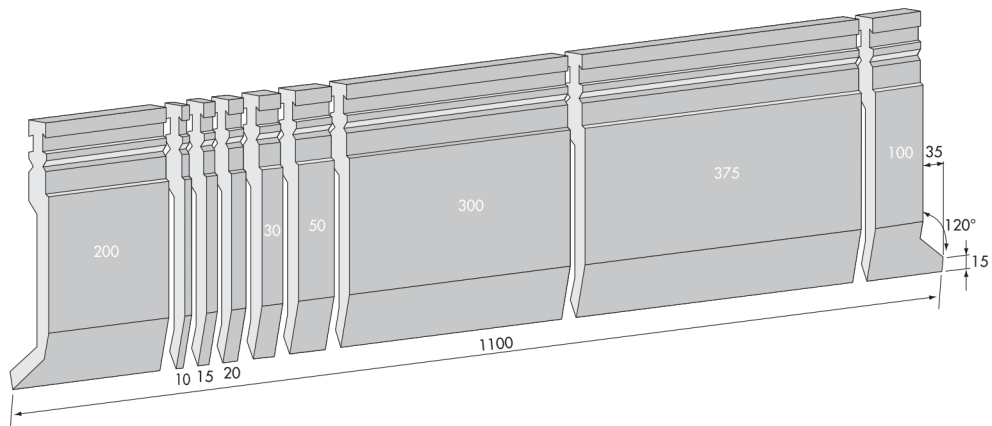

BEYELER TYPE

RKS-03-BP175-88-R1-A-RFA -1000

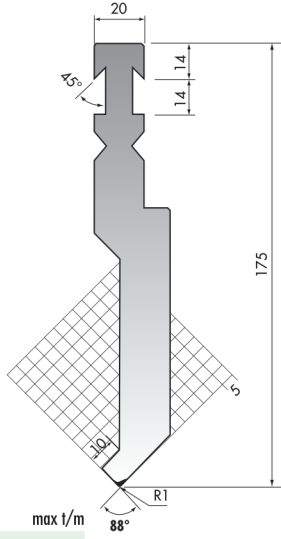

175-88-R1-A-RFA 100

RKS-03-BP175-88-R1-B-RFA -1000

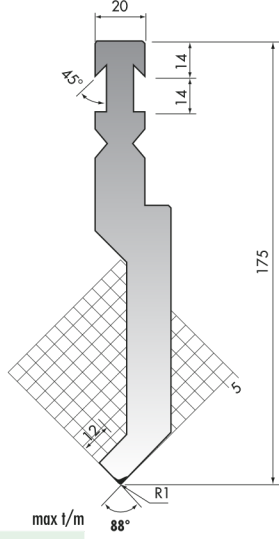

175-88-R1-B-RFA 100

RKS-03-BP175-88-R15-RFA -1000

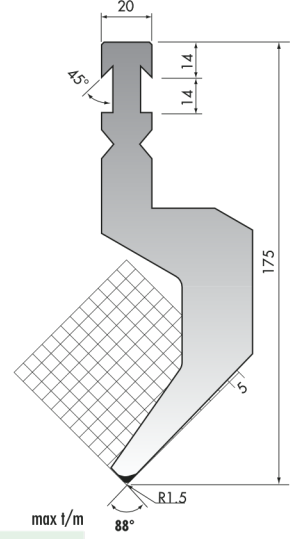

175-88-R15-RFA 50

RKS-03-BP155-85-R08-R-1000

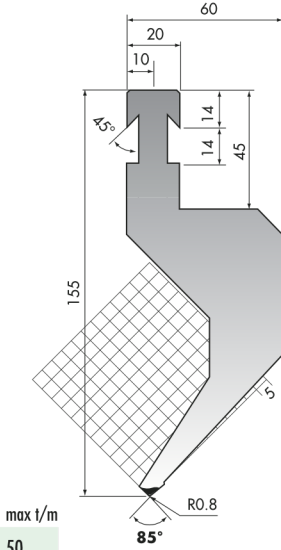

155-85-R08-R 50

RKS-03-BP155-85-R08-S-1000

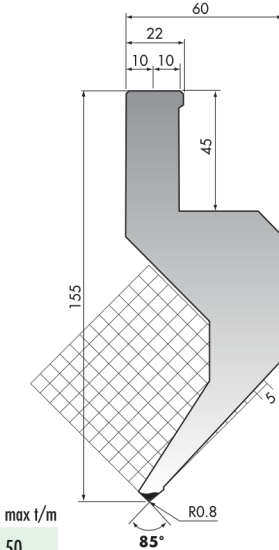

155-85-R08-S 50

RKS-03-BP155-85-R1-R -1000

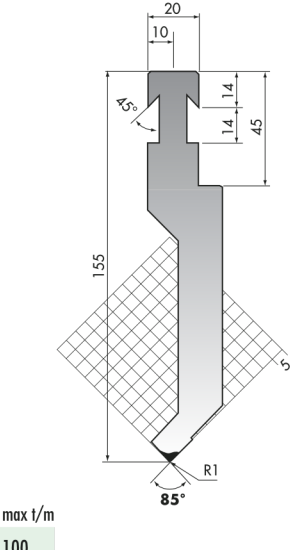

155-85-R1-R 100

RKS-03-BP155-85-R1-S-1000

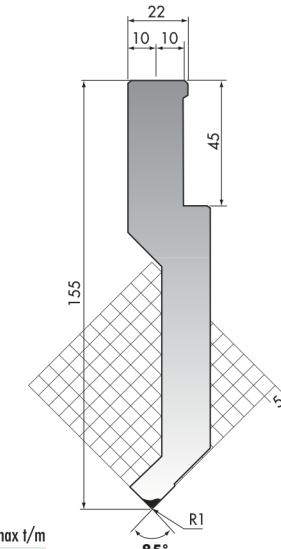

155-85-R1-S 100

RKS-03-BP155-85-R15-R-1000

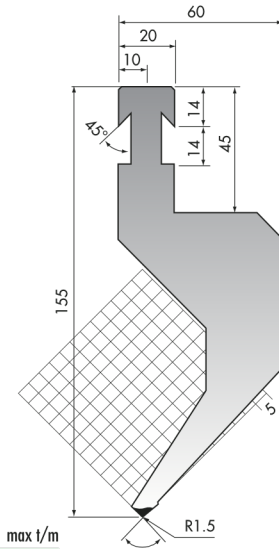

155-85-R15-R 50

RKS-03-BP155-85-R15-S-1000

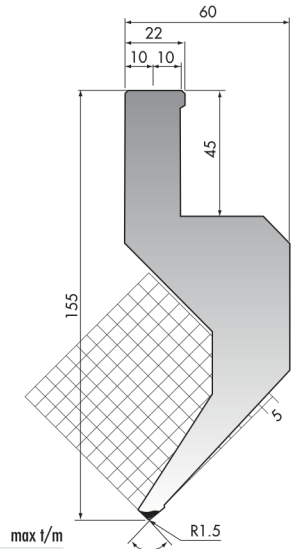

155-85-R15-S 50

BEYELER TYPE

RKS-03-BP175-30-R1-RFA-1000

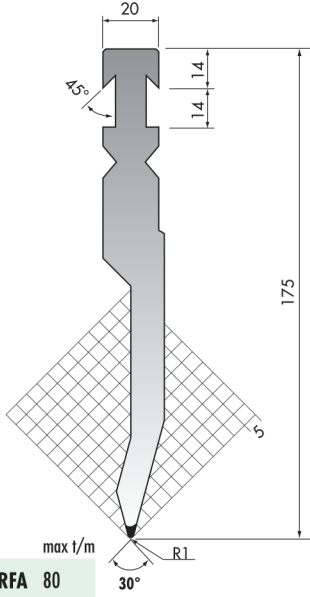

175-30-R1-RFA 80

RKS-03-BP155-30-R1-R-1000

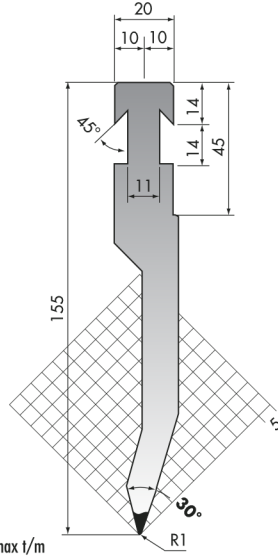

155-30-R1-R 80

RKS-03-BP155-30-R1-S-1000

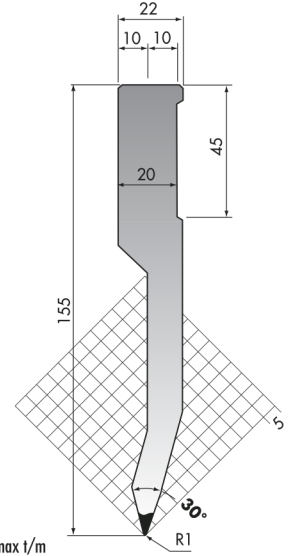

155-30-R1-S 80

RKS-03-BP155-28-R1-R-1000

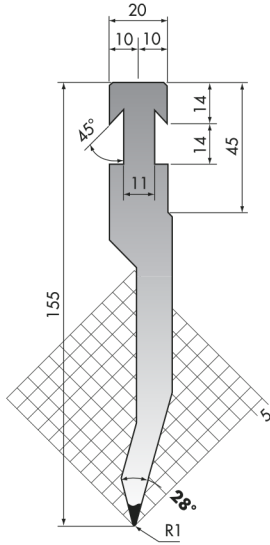

155-28-R1-R 80

RKS-03-BP155-28-R1-S-1000

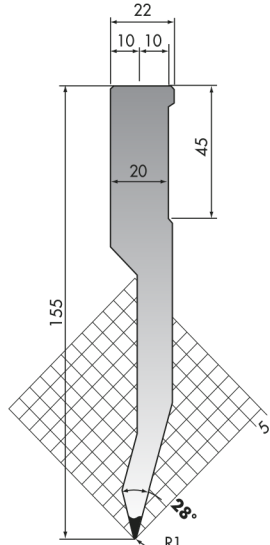

155-28-R1-S 80

RKS-03-BP155-28-R3-R-1000

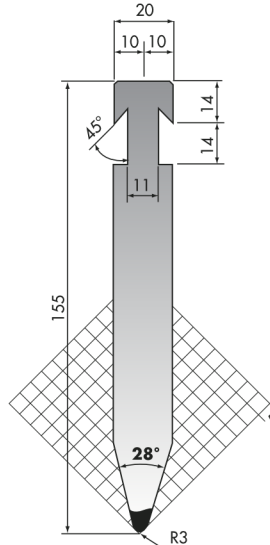

155-28-R3-R 100

RKS-03-BP155-28-R3-S-1000

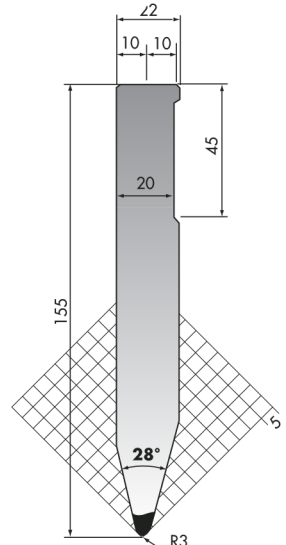

155-28-R3-S 100

RKS-03-BP

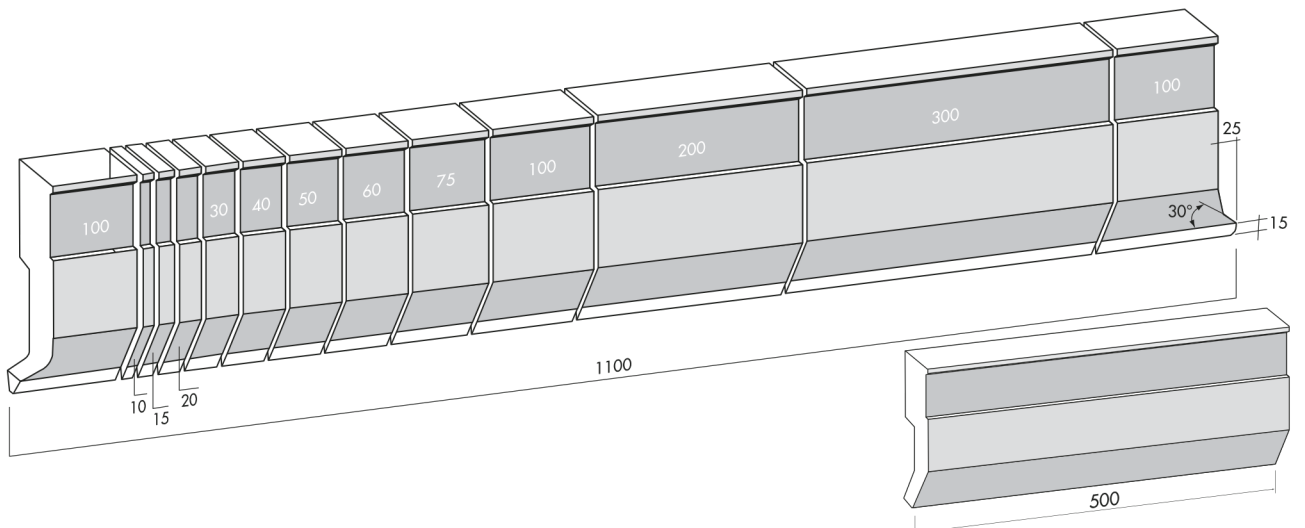

BEYELER TYPE

RKS-03-BMR-55-60-65-85-(6-8-10-12-16-20-24-32-40-50-60-80-100)-30-60-80-85-88-90-1000

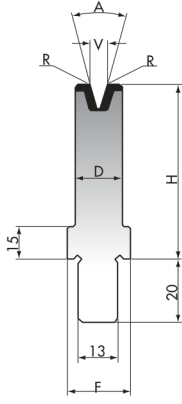

	V mm	A°	R mm	D mm	H mm	F mm	max t/m
10-88	10	88	1	20	55	25	110
12-88	12	88	1,5	20	55	25	120
16-88	16	88	2	30	55	30	120
20-88	20	88	2	30	55	30	110
24-88	24	88	3	40	55	40	120

	V mm	A°	R mm	D mm	H mm	F mm	max t/m
32-85	32	85	4	50	55	50	120
40-85	40	85	4	55	55	55	120
80-80	80	80	10	100	65	100	170
100-80	100	80	12	125	85	125	230
40-60	40	60	5	55	55	55	130
50-60	50	60	5	70	55	70	120
60-60	60	60	7	80	65	80	110

	V mm	A°	R mm	D mm	H mm	F mm	max t/m
06-90	6	90	0,4	15	55	25	115
08-90	8	90	0,5	15	55	25	110
10-90	10	90	1	20	55	25	110
12-90	12	90	1,5	20	55	25	120
16-90	16	90	2	30	55	30	120

	V mm	A°	R mm	D mm	H mm	F mm	max t/m 90°	max t/m 60°	max t/m 30°
06-30	6	30	0,6	15	55	25	90	50	35
08-30	8	30	0,8	15	55	25	70	40	20
10-30	10	30	1	20	55	25	80	50	35
12-30	12	30	1,5	20	55	25	70	45	30
16-30	16	30	2	30	55	30	105	65	45
20-30	20	30	2,5	35	55	35	105	70	50
24-30	24	30	3	40	55	40	105	70	55
32-30	32	30	4	60	60	60	150	80	65

RKS-03-BMR

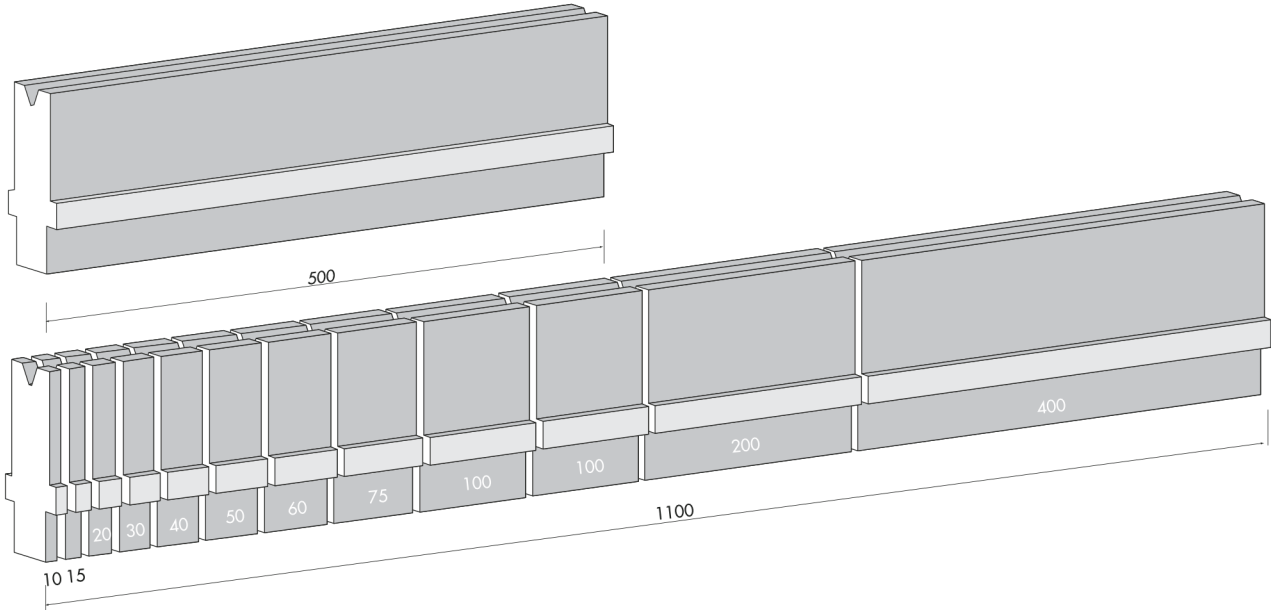

BEYELER TYPE

RKS-03-(P+M)-28-525

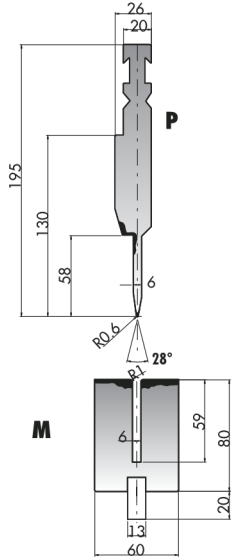

max t/m
A B

195.28.6		
195.28.6	50	100
195.28.6	50	100

RKS-03-(P+M)-28-525

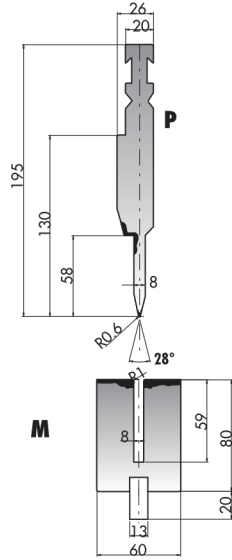

max t/m
A B

195.28.8		
195.28.8	80	100
195.28.8	50	100

RKS-03-(P+M)-24-525

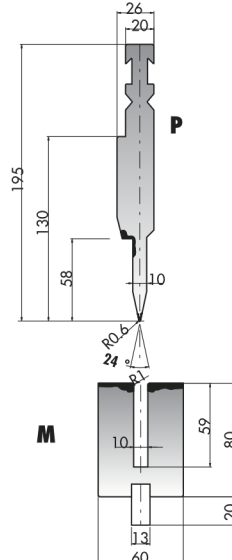

max t/m
A B

195.24.10		
195.24.10	80	100
195.24.10	50	100

RKS-03-(P+M)-24-525

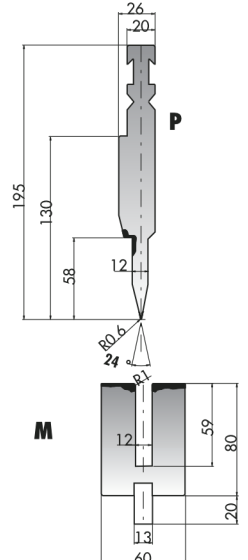

max t/m
A B

195.24.12		
195.24.12	80	100
195.24.12	50	100

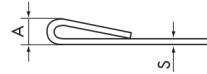
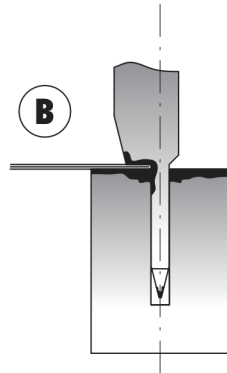
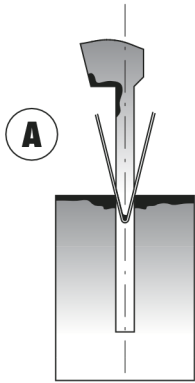

S	A	R.45 Kgf/mm ²	R.70 Kgf/mm ²
mm	mm	t/m	t/m
0,6	3,0	9	15
0,8	3,0	12	20
1,0	3,5	15	25
1,25	3,5	17	26
1,5	4,6	22	38
2,0	5,5	30	50

S	A	R.45 Kgf/mm ²	R.70 Kgf/mm ²
mm	mm	t/m	t/m
0,6	1,2	23	35
0,8	1,6	32	50
1,0	2,0	40	60
1,25	2,5	50	80
1,5	3,0	63	95
2,0	4,0	80	130

BPR

195.28.6/F
195.28.8/F
195.28.8/F

195.28.8/F
195.28.6/F
195.28.6/F

195.24.10/F
195.24.10/F
195.24.10/F

195.24.12/F
195.24.12/F
195.24.12/F

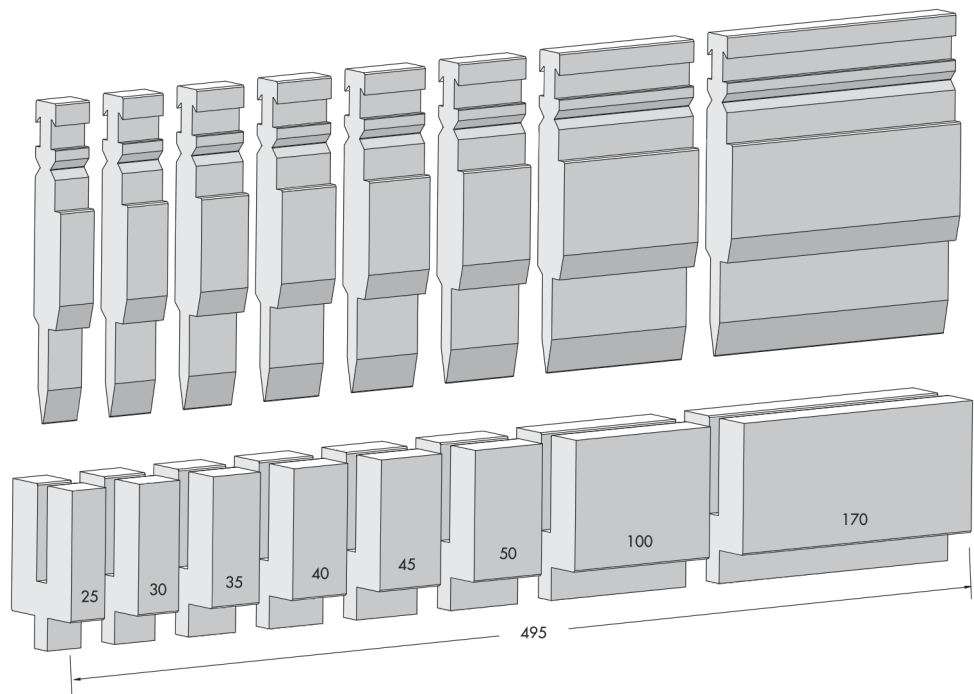

BEYELER TYPE

RKS-03-BPR150-P10-10-RFA-522

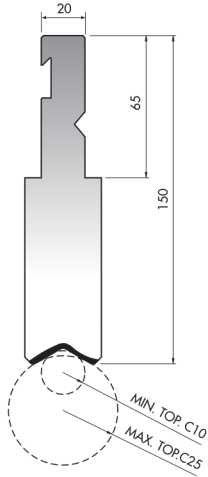

max t/m

P10-10-RFA 100

RKS-03-BPR150-P10-15-RFA-522

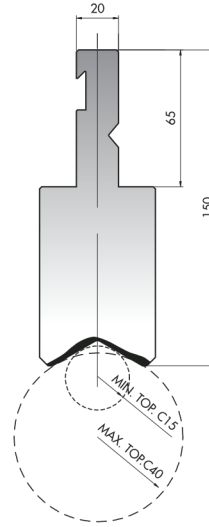

max t/m

P10-15-RFA 100

RKS-03-BPR

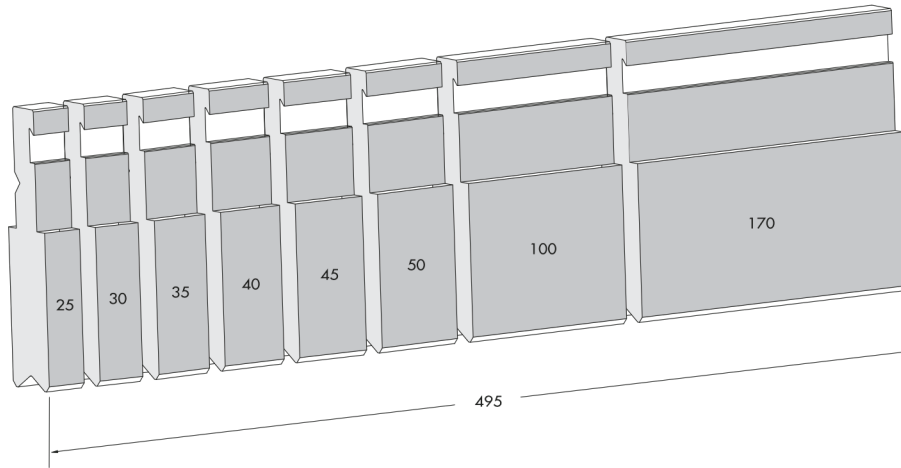

RKS-03-TOP.C-(10-12.5-15-17.5-20-25-30-35-40)-525

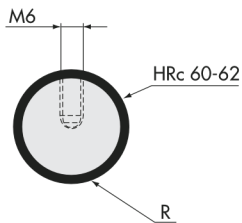

	R mm	max t/m
TOP.C10	10	100
TOP.C12.5	12,5	100
TOP.C15	15	100
TOP.C17.5	17,5	100

	R mm	max t/m
TOP.C20	20	100
TOP.C25	25	100
TOP.C30	30	100
TOP.C35	35	100
TOP.C40	40	100

RKS-03-TOP.C

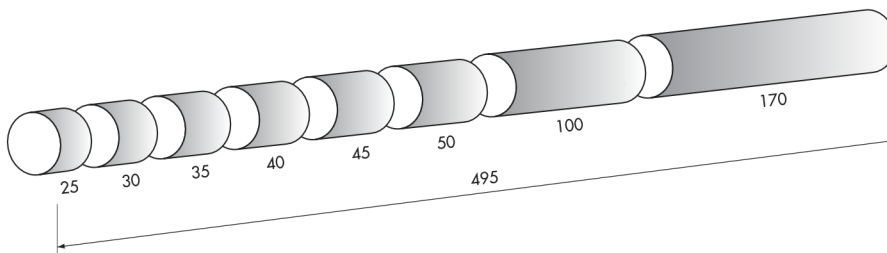

BEYELER TYPE

RKS-03-BPZ-835-415

	mm	max t/m
RKS-03-BPZ	835	100
RKS-03-BPZ/C	415	100

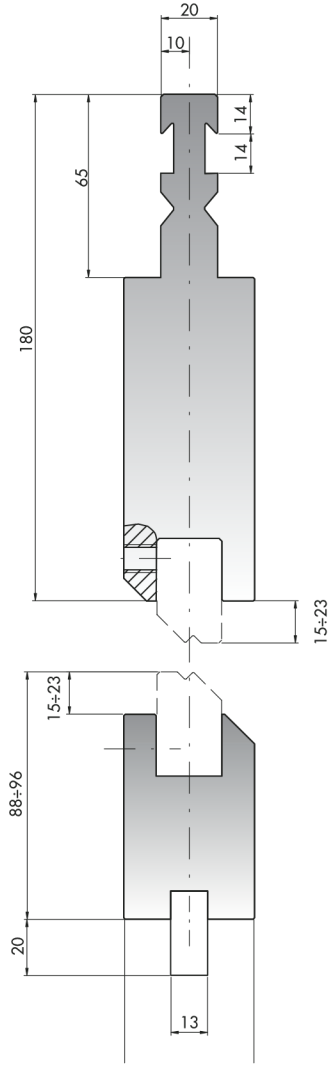

RKS-03-CEZ-(1-1.5-2-2.5-3-4-4.5-5-5.5-6-6.5-7-7.5-8-9-10-11-12-13-14-15)-90-140-150-160-835-415

	Z mm	B°	S* mm	max t/m
1	1	160°	1,2	100
1.5	1,5	160°	1,5	100
2	2	150°	1,4	100
2.5	2,5	140°	1,3	100
3	3	90°	1	100
3.5	3,5	90°	1	100
4	4	90°	1,2	100
4.5	4,5	90°	1,2	100
5	5	90°	1,3	100
5,5	5,5	90°	1,4	100
6	6	90°	1,5	100
6.5	6,5	90°	1,5	100
7	7	90°	1,5	100
7.5	7,5	90°	1,6	100
8	8	90°	1,6	100

* Fe Rmax=42 kg/mm²



	Z mm	B°	S* mm	max t/m
9	9	90°	1,8	100
10	10	90°	1,8	100
11	11	90°	2	100
12	12	90°	2	100
13	13	90°	2	100
14	14	90°	2	100
15	15	90°	2,3	100

* Fe Rmax=42 kg/mm²

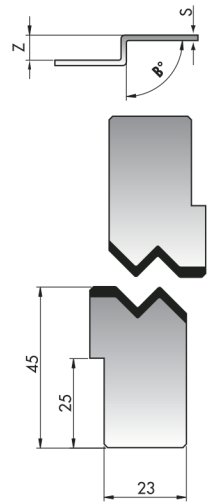

GASPARINI TYPE

RKS-04-GASP200-80-R08-835

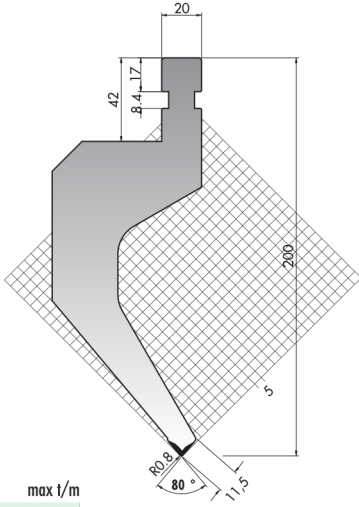

max t/m
80-R08 80

RKS-04-GASP200-60-R08-835

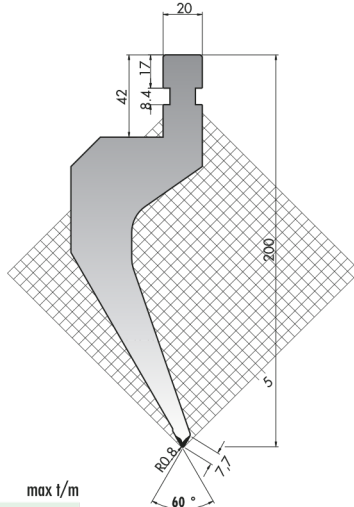

max t/m
60-R08 65

RKS-04-GASP200-26-R08-835

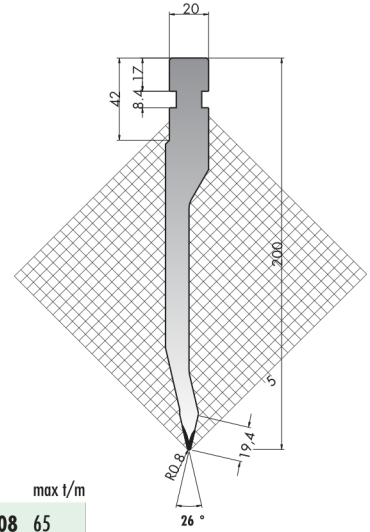

max t/m
26-R08 65

RKS-04-GASP200-80-R15-835

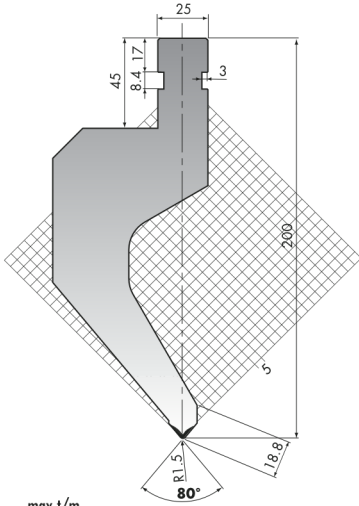

max t/m
80-R15 100

RKS-04-GASP200-60-R15-835

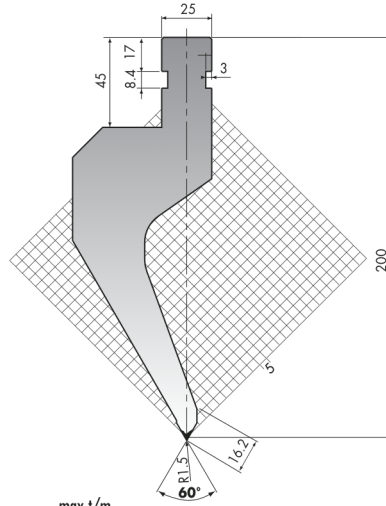

max t/m
60-R15 100

RKS-04-GASP200-26-R1-835

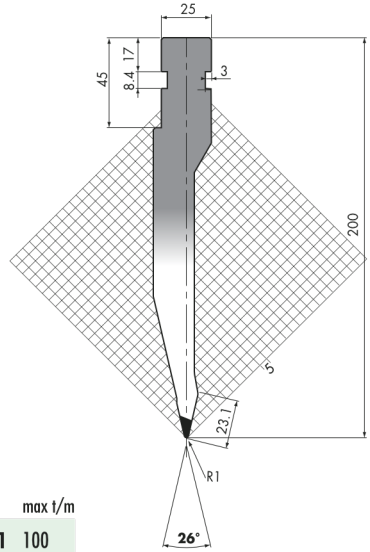

max t/m
26-R1 100

RKS-04-GASP200-80-R15-30-835

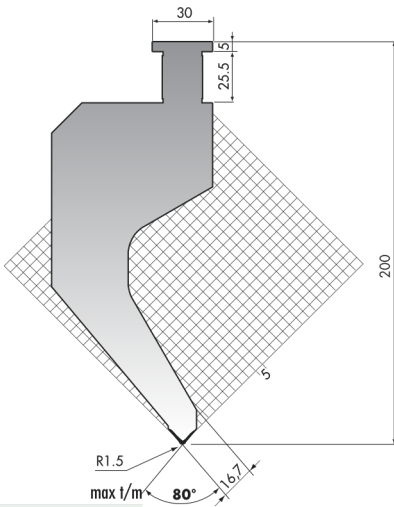

max t/m
80-R15-30 100

RKS-04-GASP200-26-R3-30-835

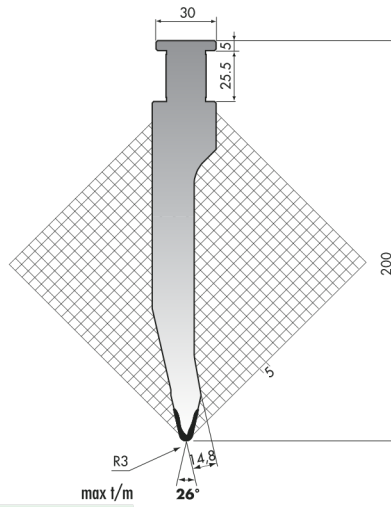

max t/m
26-R3-30 130

GASPARINI TYPE

RKS-04-GASP

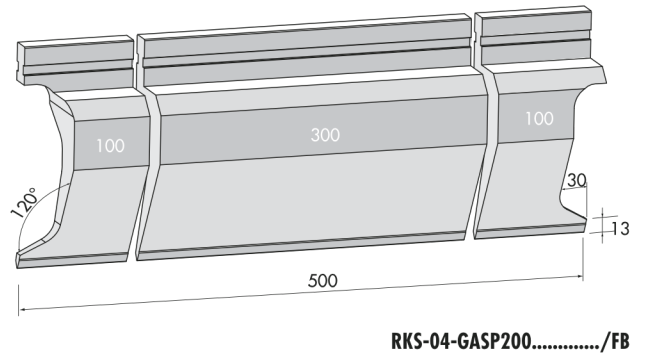
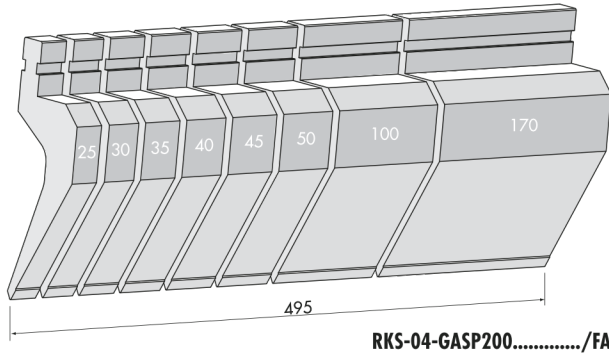

RKS-04-C2000/S C2500/S C3000/S C4000/S

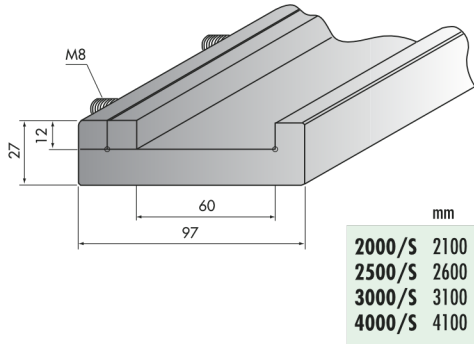

RKS-04-C1050/R

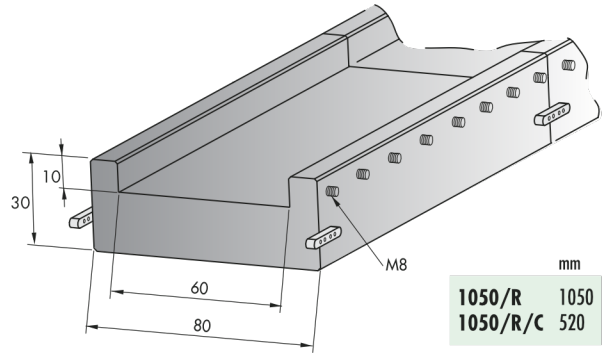

RKS-04-C1050/RS-1050-520

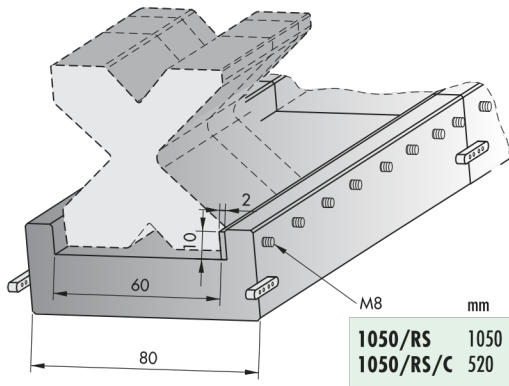

RKS-04-C 1050-90-1050-520

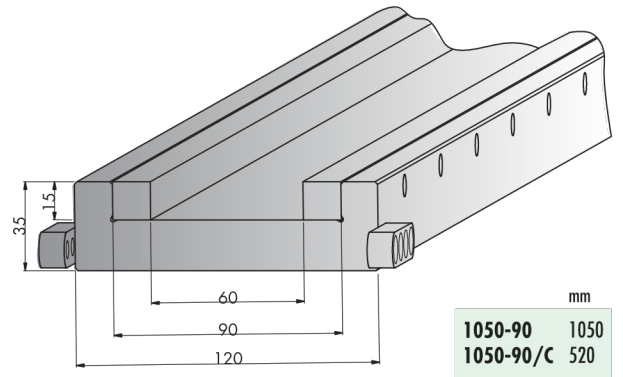

RKS-04-01-AD14-150

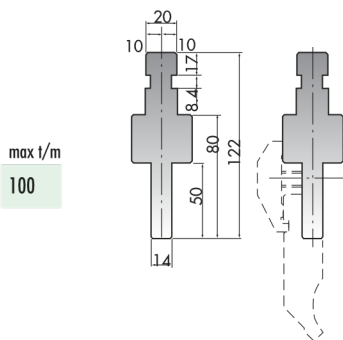

RKS-04-01-CTS60-835-415

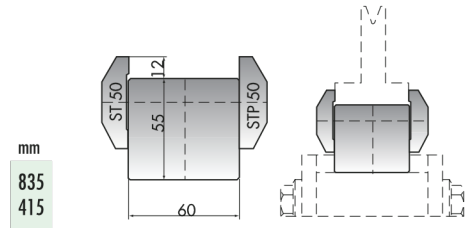

RKS-04-01-02-03-AD5-500-1000

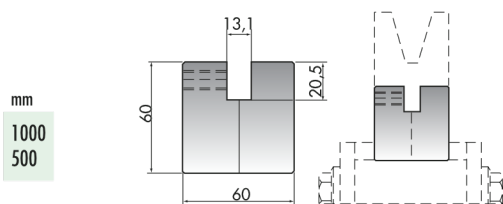

RKS-04-01-02-03-AD6-500-1000

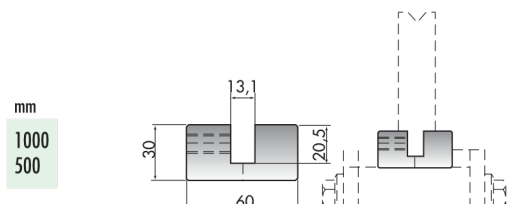

COLGAR TYPE

RKS-05-PAC195-85-R08-525

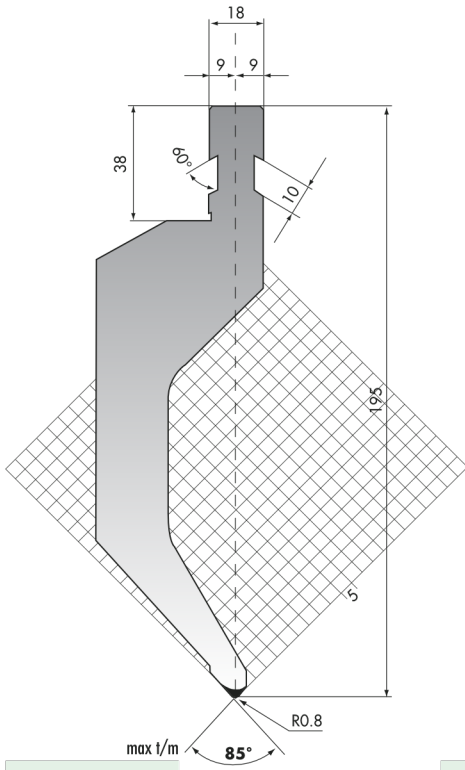

195-85-R08 100

RKS-05-PAC195-60-R08-525

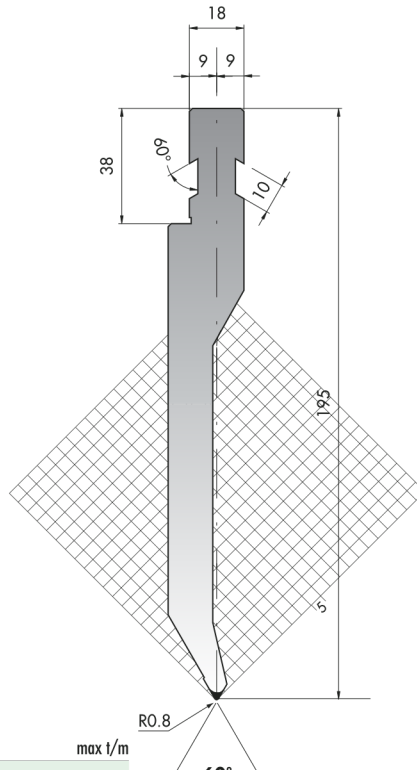

195-60-R08 80

RKS-05-PAC195-26-R08-525

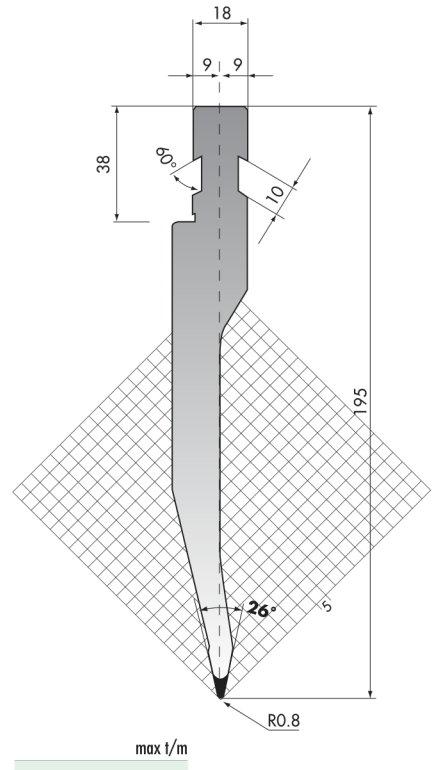

195-26-R08 100

RKS-05-PAC

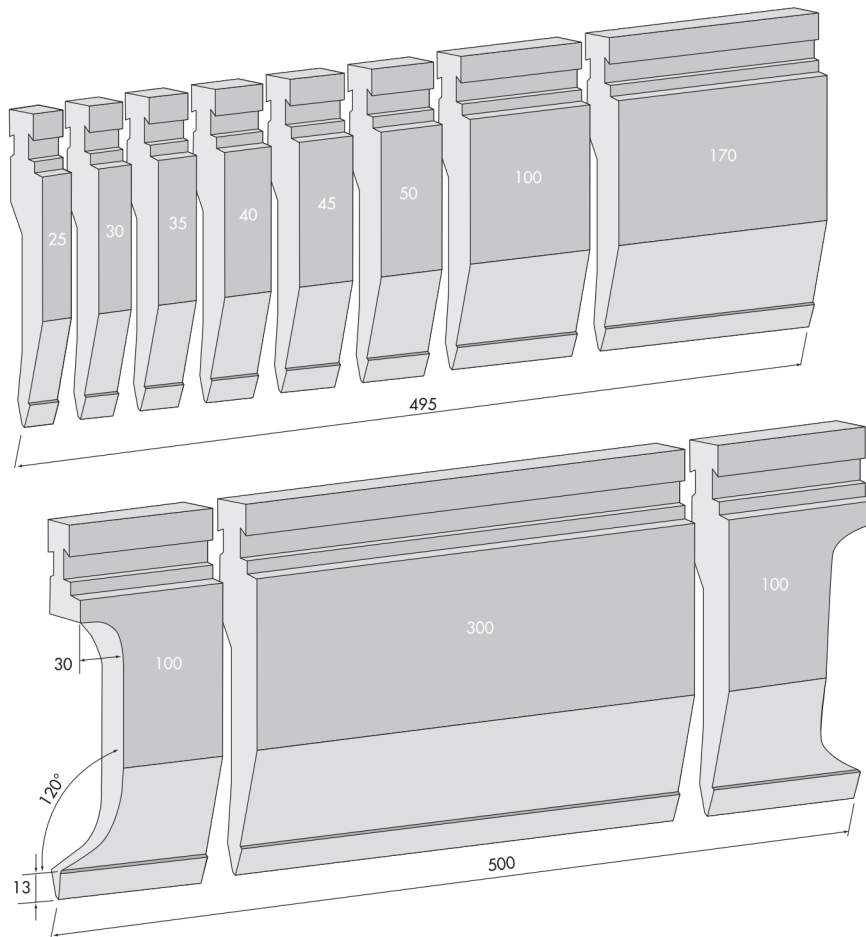

COLGAR TYPE

RKS-05-PAC175-14-830

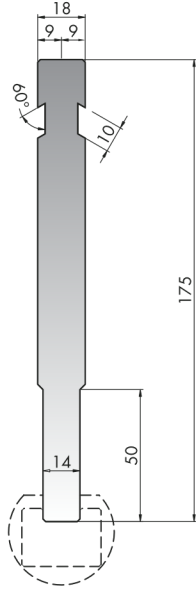

RKS-05-C2000/S C2500/S C3000/S C4000/S

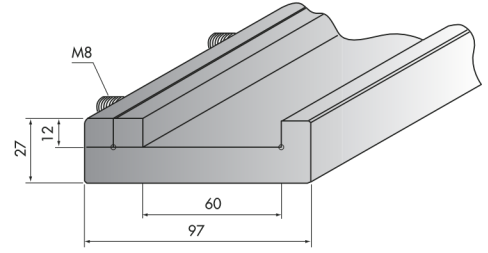

	mm
2000/S	2100
2500/S	2600
3000/S	3100
4000/S	4100

RKS-05-C1050/R-520-1050

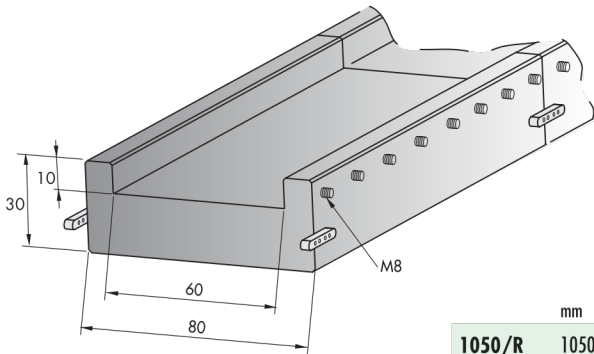

	mm
1050/R	1050
1050/R/C	520

RKS-05-C1050/RS-520-1050

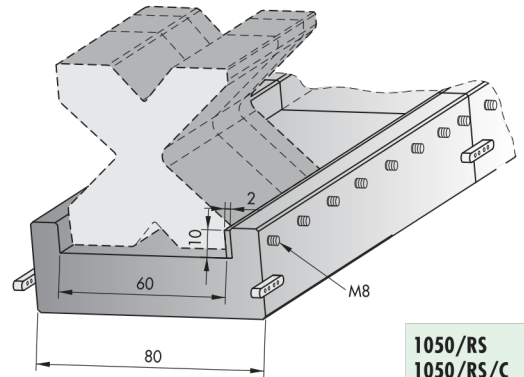

	mm
1050/RS	1050
1050/RS/C	520

RKS-05-01-AD12-150

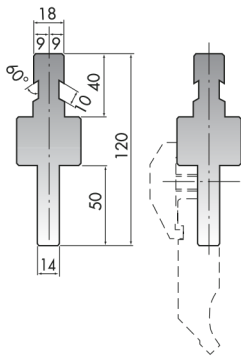

max t/m	
12	100

RKS-05-01-CTS60-835-415

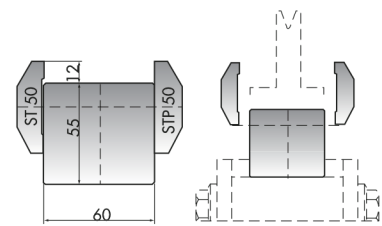

	mm
60	835
60/C	415

RKS-05-01-02-AD5-500-1000

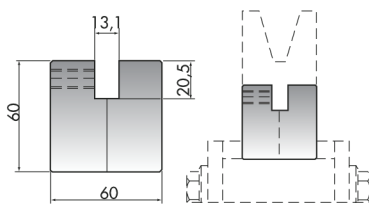

	mm
5	1000
5/C	500

RKS-05-01-02-03-AD6-500-1000

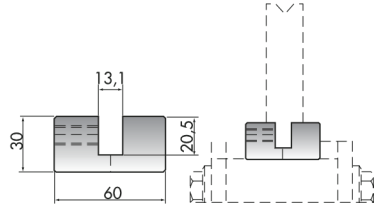

	mm
6	1000
6/C	500

LVD TYPE

RKS-06-LP-(A-B-C-D)-180-78-R1-A-508

- A-180-78-R1-A
- B-180-78-R1-A
- C-180-78-R1-A
- D-180-78-R1-A

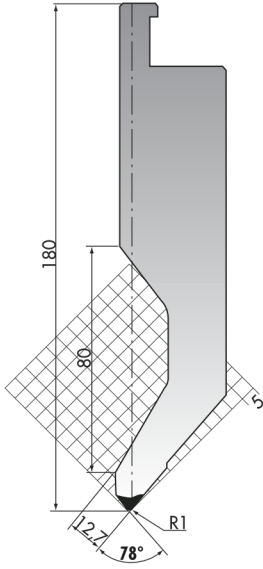

RKS-06-LP-(A-B-C-D)-180-78-B-508

- A-180-78-R1-B
- B-180-78-R1-B
- C-180-78-R1-B
- D-180-78-R1-B

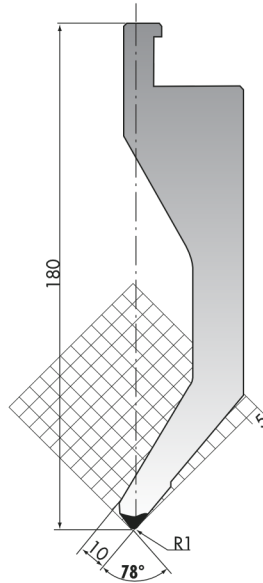

RKS-06-LP-(A-B-C-D)-180-78-R1-C-508

- A-80-78-R1-C
- B-180-78-R1-C
- C-180-78-R1-C
- D-180-78-R1-C

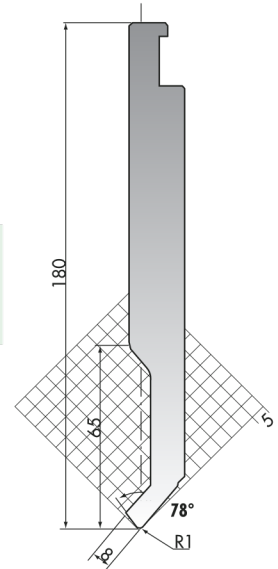

RKS-06-LP-(A-B-C-D)-180-78-R2-508

- A-180-78-R2
- B-180-78-R2
- C-180-78-R2
- D-180-78-R2

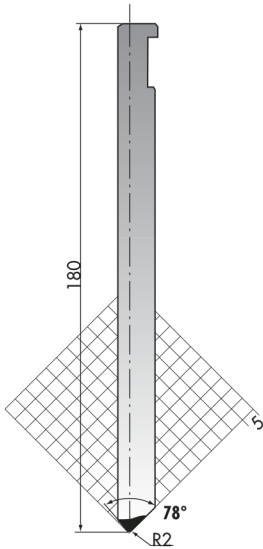

RKS-06-LP-(A-B-C-D)-180-26-R1-508

- A-180-26-R1
- B-180-26-R1
- C-180-26-R1
- D-180-26-R1

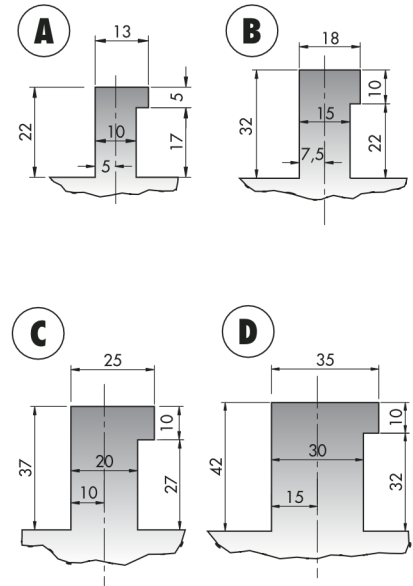
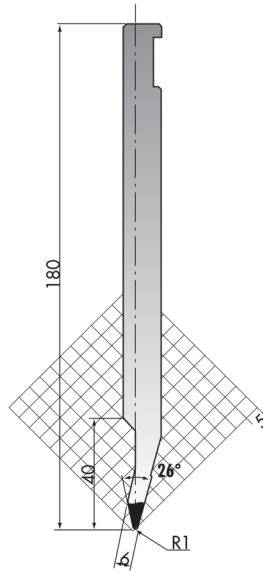

RKS-06-LP

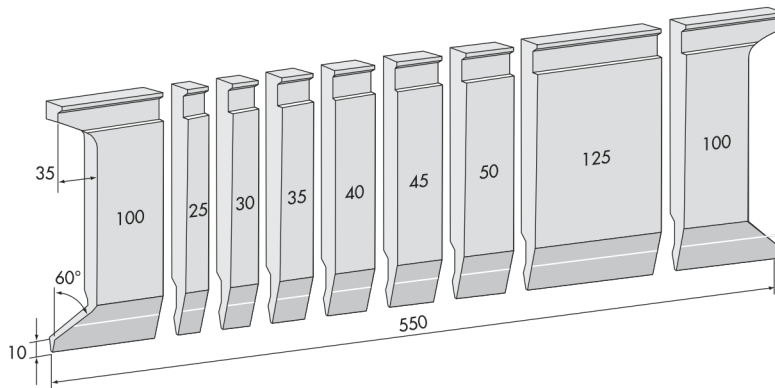

LVD TYPE

RKS-06-LM90-(06-08-10-12-16-20-24-30-40-50-60-80)-78-508

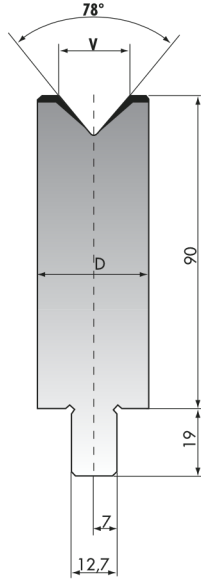

	V mm	D mm	max l/m
06-78	6	12	40
08-78	8	12	40
10-78	10	14	50
12-78	12	18	60
16-78	16	25	80
20-78	20	32	100
24-78	24	32	100
30-78	30	40	110
40-78	40	50	130
50-78	50	60	150
60-78	60	70	150
80-78	80	90	150

RKS-06-LM90-(06-08-10-12-16-20-24)-30-508

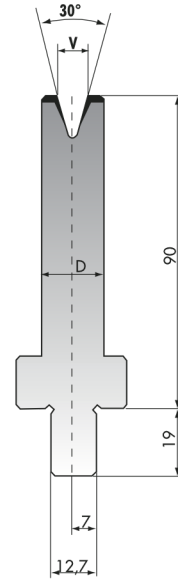

	V mm	D mm	max l/m
06-30	6	16	20
08-30	8	18	22
10-30	10	25	30
12-30	12	32	38
16-30	16	32	38
20-30	20	40	38
24-30	24	50	55

RKS-06-LM

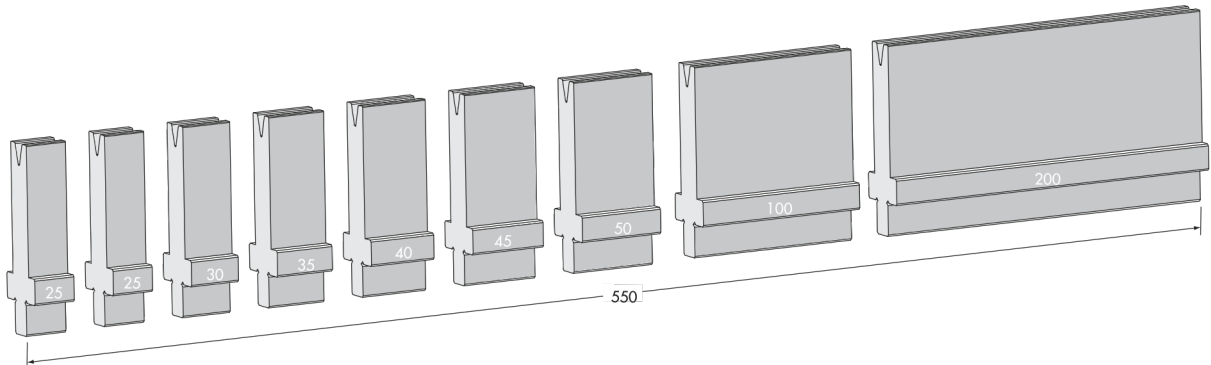

LVD TYPE

RKS-06-(P+M)-20-525

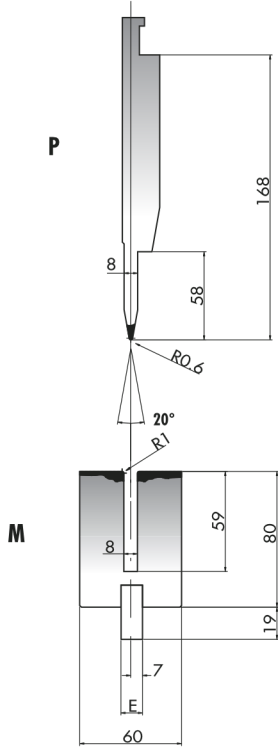

E mm max t/m
 A B

190.20.8-12	A	12		
190.20.8	A		80	100
190.20.8-12	A	12	50	100

190.20.8-12	B	12		
190.20.8	B		80	100
190.20.8-12	B	12	50	100

190.20.8-12	C	12		
190.20.8	C		80	100
190.20.8-12	C	12	50	100

190.20.8-12	D	12		
190.20.8	D		80	100
190.20.8-12	D	12	50	100

190.20.8-12.7	A	12,7		
190.20.8	A		80	100
190.20.8-12.7	A	12,7	50	100

190.20.8-12.7	B	12,7		
190.20.8	B		80	100
190.20.8-12.7	B	12,7	50	100

190.20.8-12.7	C	12,7		
190.20.8	C		80	100
190.20.8-12.7	C	12,7	50	100

190.20.8-12.7	D	12,7		
190.20.8	D		80	100
190.20.8-12.7	D	12,7	50	100

RKS-06-(P+M)-20-525

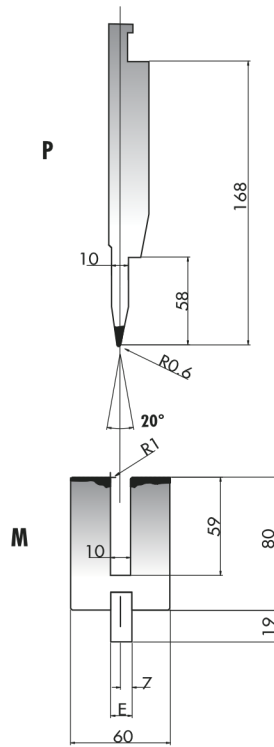

E mm max t/m
 A B

190.20.10-12	A	12		
190.20.10	A		80	100
190.20.10-12	A	12	50	100

190.20.10-12	B	12		
190.20.10	B		80	100
190.20.10-12	B	12	50	100

190.20.10-12	C	12		
190.20.10	C		80	100
190.20.10-12	C	12	50	100

190.20.10-12	D	12		
190.20.10	D		80	100
190.20.10-12	D	12	50	100

190.20.10-12.7	A	12,7		
190.20.10	A		80	100
190.20.10-12.7	A	12,7	50	100

190.20.10-12.7	B	12,7		
190.20.10	B		80	100
190.20.10-12.7	B	12,7	50	100

190.20.10-12.7	C	12,7		
190.20.10	C		80	100
190.20.10-12.7	C	12,7	50	100

190.20.10-12.7	D	12,7		
190.20.10	D		80	100
190.20.10-12.7	D	12,7	50	100

RKS-06-(P+M)-20-525

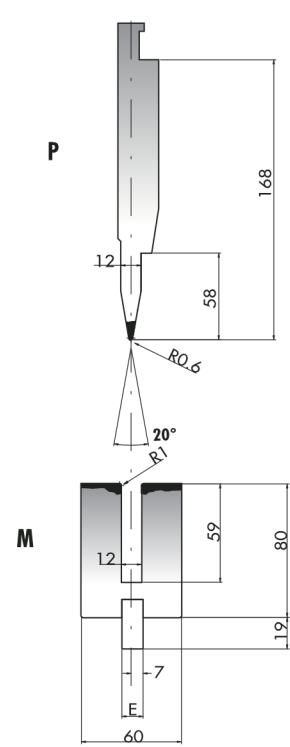

E mm max t/m
 A B

190.20.12-12	A	12		
190.20.12	A		80	100
190.20.12-12	A	12	50	100

190.20.12-12	B	12		
190.20.12	B		80	100
190.20.12-12	B	12	50	100

190.20.12-12	C	12		
190.20.12	C		80	100
190.20.12-12	C	12	50	100

190.20.12-12	D	12		
190.20.12	D		80	100
190.20.12-12	D	12	50	100

190.20.12-12.7	A	12,7		
190.20.12	A		80	100
190.20.12-12.7	A	12,7	50	100

190.20.12-12.7	B	12,7		
190.20.12	B		80	100
190.20.12-12.7	B	12,7	50	100

190.20.12-12.7	C	12,7		
190.20.12	C		80	100
190.20.12-12.7	C	12,7	50	100

190.20.12-12.7	D	12,7		
190.20.12	D		80	100
190.20.12-12.7	D	12,7	50	100

LVD-WILA TYPE

RKS-06-LPR.S-195.28.8-525

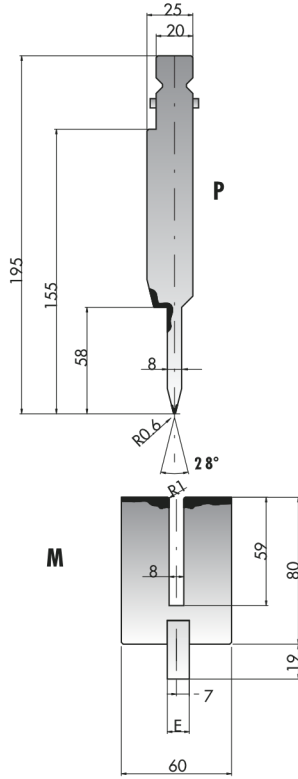

E mm max t/m
 A B

195.28.8-12	12		
195.28.8		80	100
195.28.8-12	12	50	100
195.28.8-12.7	12,7		
195.28.8		80	100
195.28.8-12.7	12,7	50	100

RKS-06-LPR.S-195.24.10-525

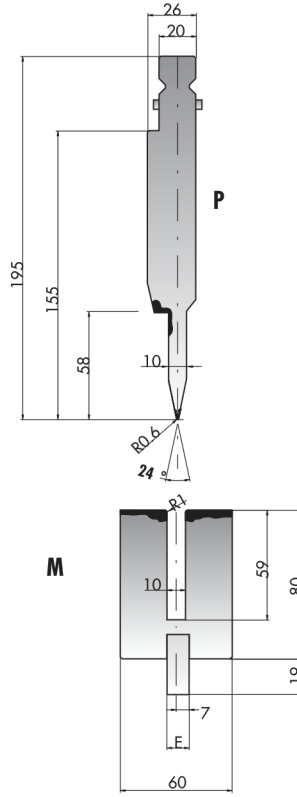

E mm max t/m
 A B

195.24.10-12	12		
195.24.10		80	100
195.24.10-12	12	50	100
195.24.10-12.7	12,7		
195.24.10		80	100
195.24.10-12.7	12,7	50	100

RKS-06-LPR.S-195.24.12-525

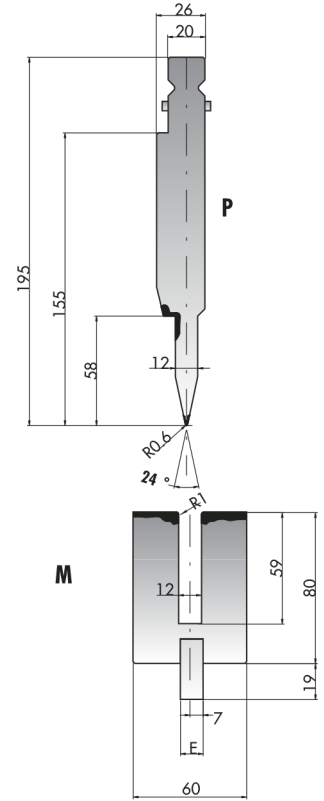

E mm max t/m
 A B

195.24.12-12	12		
195.24.12		80	100
195.24.12-12	12	12	100
195.24.12-12.7	12,7		
195.24.12		80	100
195.24.12-12.7	12,7	50	100

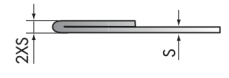
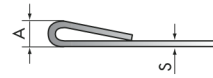
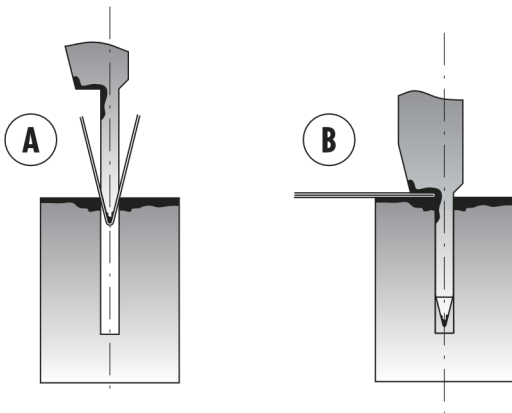

S	A	R.45 Kgf/mm ²	R.70 Kgf/mm ²
mm	mm	t/m	t/m
0,6	3,0	9	15
0,8	3,0	12	20
1,0	3,5	15	25
1,25	3,5	17	26
1,5	4,6	22	38
2,0	5,5	30	50

S	A	R.45 Kgf/mm ²	R.70 Kgf/mm ²
mm	mm	t/m	t/m
0,6	1,2	23	35
0,8	1,6	32	50
1,0	2,0	40	60
1,25	2,5	50	80
1,5	3,0	63	95
2,0	4,0	80	130

LVD-WILA TYPE

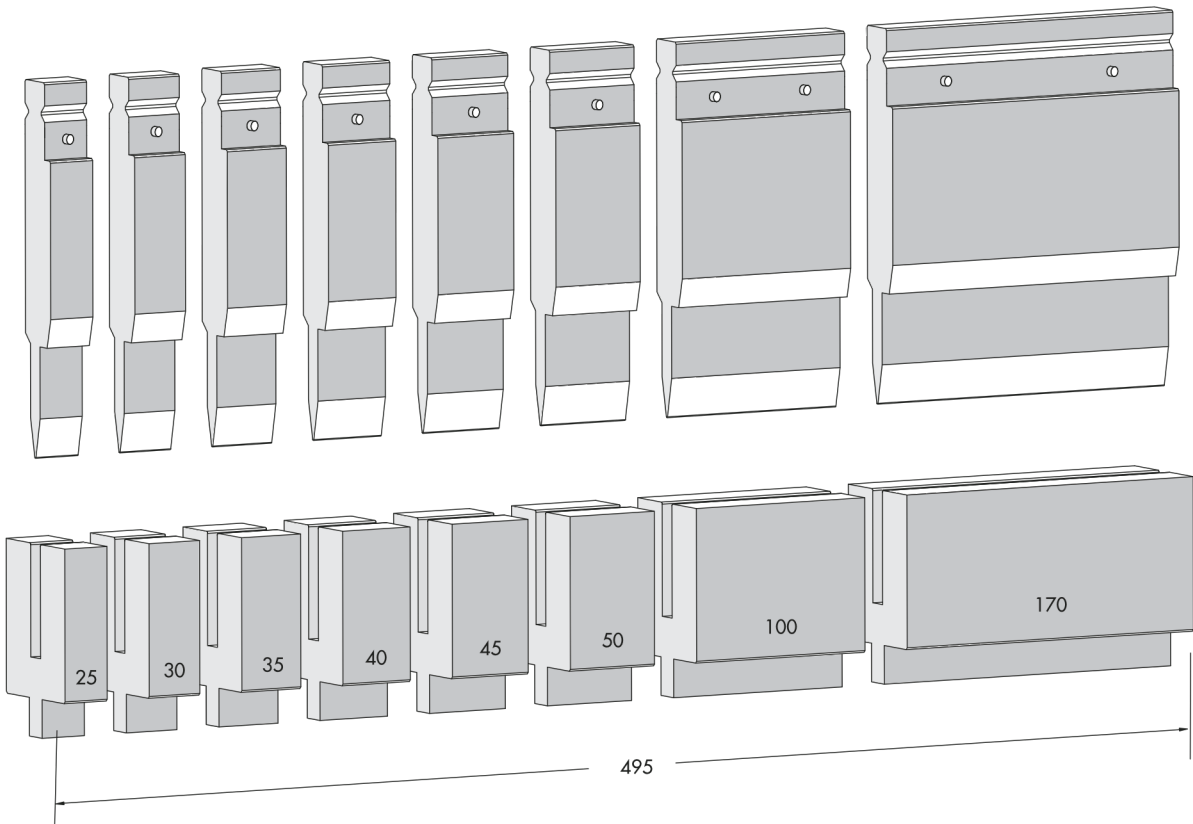

LVD-WILA TYPE

RKS-06-01-AD1-(A-B-C-D)-150

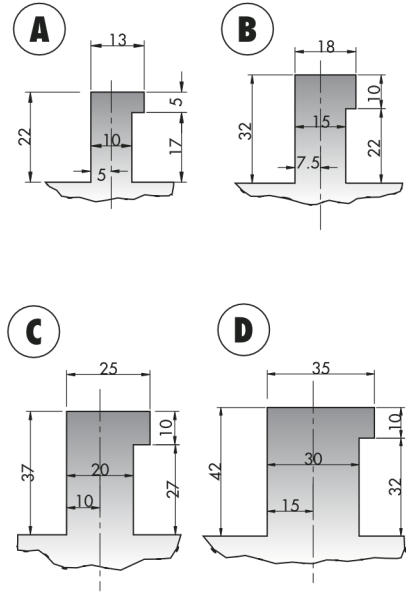
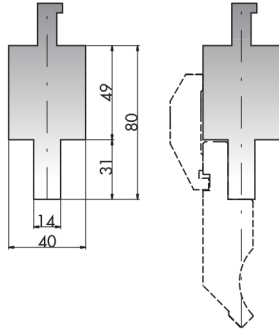

	max t/m
A	100
B	100
C	100
D	100

RKS-06-02-01-AD11-150

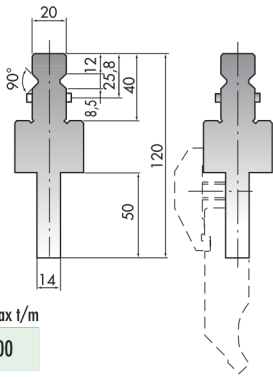

	max t/m
11	100

RKS-06-02-03-AD8-500-1000

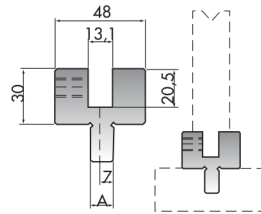

	A mm
8	12
8-12.7	12,7

RKS-06-01-AD9-835-415

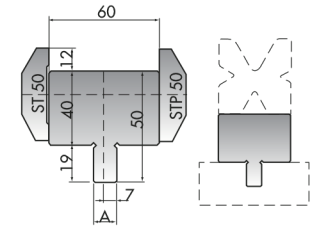

	A mm
9	12
9-12.7	12,7

RKS-06-01-A31-835-415-805

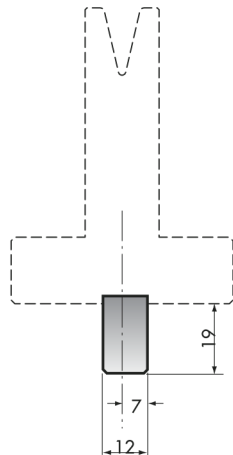

	mm
31	835
31/C	415
31/F	805

RKS-06-01-A32-835-415-805

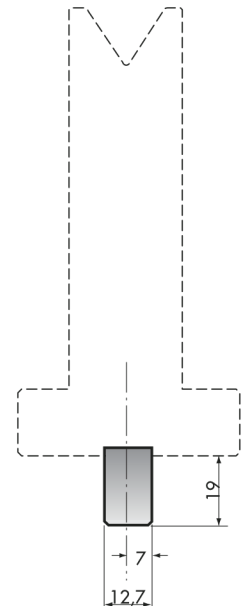

	mm
32	835
32/C	415
32/F	805

COLLY TYPE

RKS-07-CP72-90-08-1020

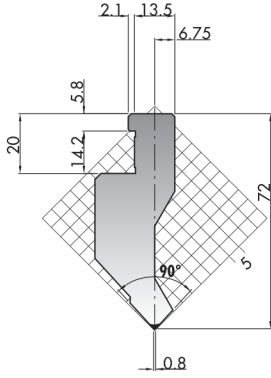

72-90-08

RKS-07-CP120-88-08-1020

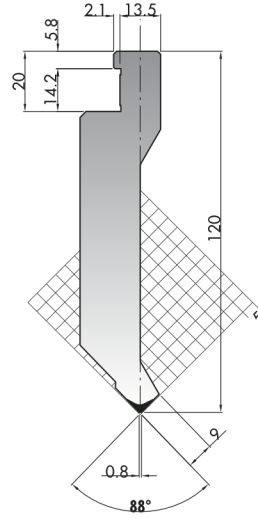

120-88-08

RKS-07-CP100-88-08-A-1020

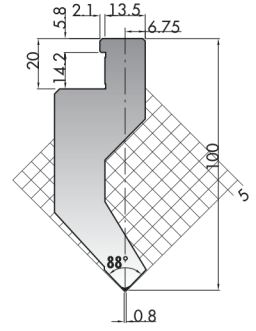

120-88-08-A

RKS-07-CP200-85-07-1020

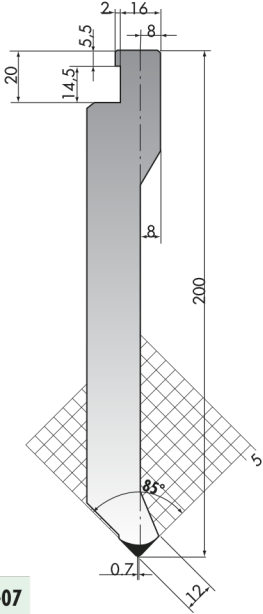

200-85-07

RKS-07-CP200-85-07-A-1020

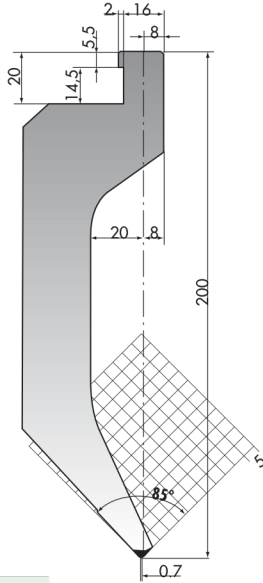

200-85-07-A

RKS-07-CP120-85-07-1020

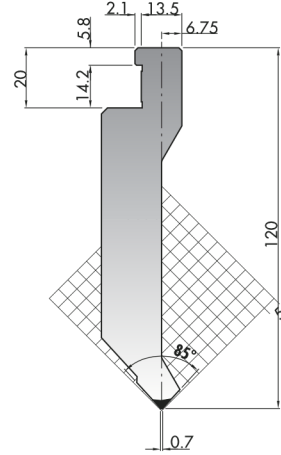

120-85-07

RKS-07-CP120-85-07-A-1020

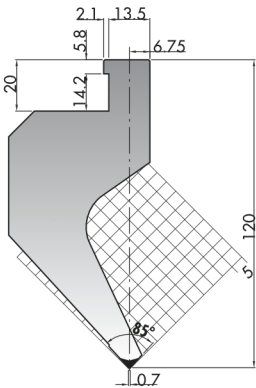

120-85-07-A

RKS-07-CP100-85-07-A-1020

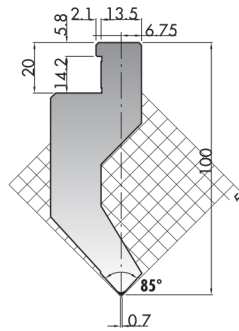

100-85-07-A

RKS-07-CP72-85-07-1020

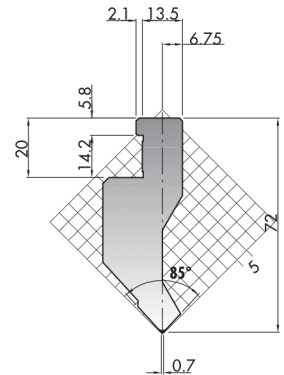

72-85-07

COLLY TYPE

RKS-07-CP200-50-R1-1020

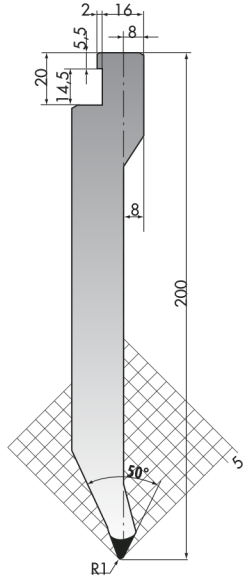

200-50-R1

RKS-07-CP200-50-R1-A-1020

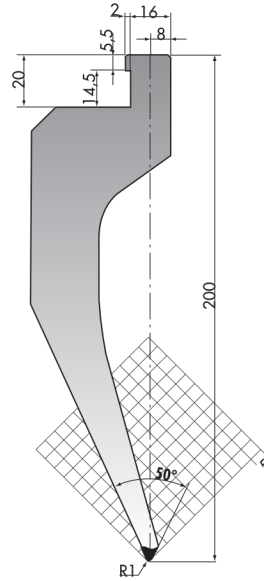

200-50-R1-A

RKS-07-CP120-50-R1-1020

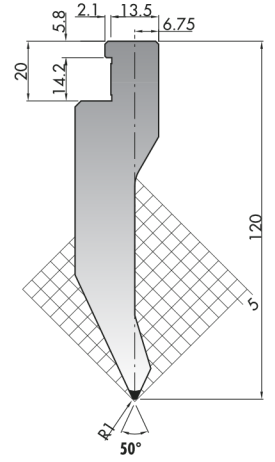

120-50-R1

RKS-07-CP120-50-R1-A-1020

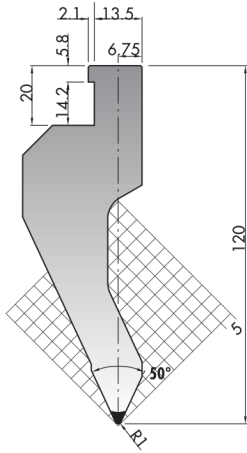

120-50-R1-A

RKS-07-CP100-50-R1-1020

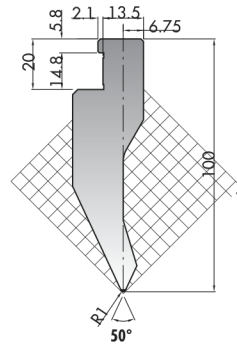

100-50-R1

RKS-07-CP200-24-R1-1020

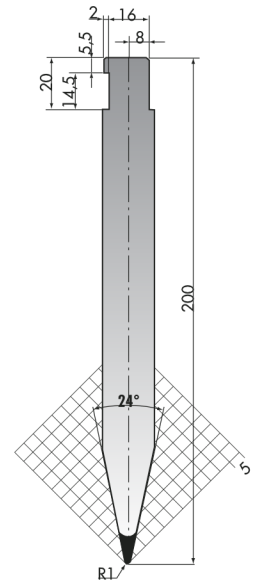

200-24-R1

RKS-07-CP

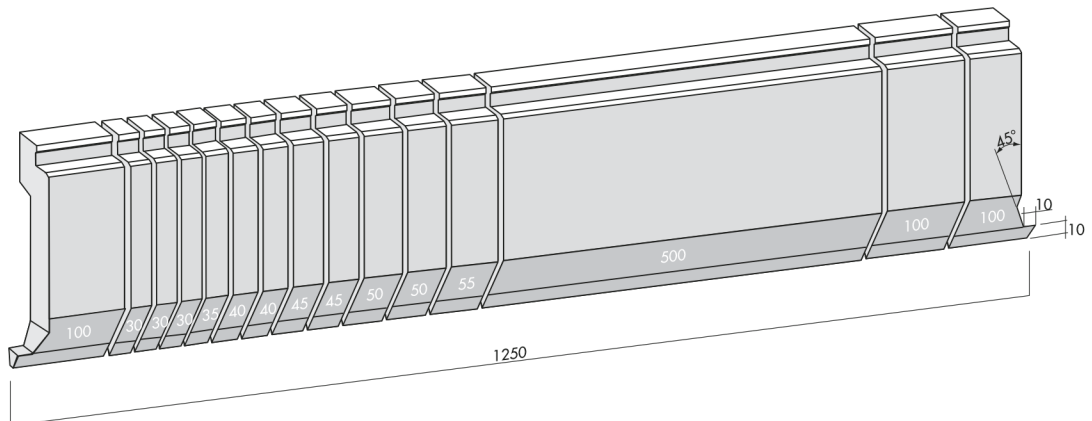

COLLY TYPE

RKS-07-M115-80-60-1020

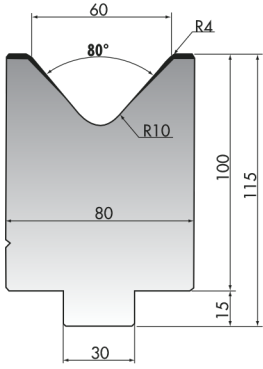

80-60

RKS-07-M115-80-80-1020

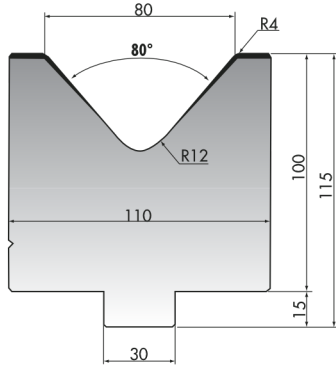

80-80

RKS-07-M115-50-16-1020

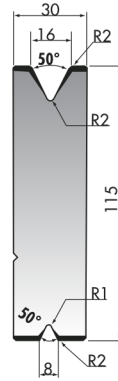

50-16

RKS-07-M115-50-22-1020

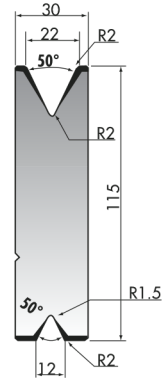

50-22

RKS-07-M115-50-30-1020

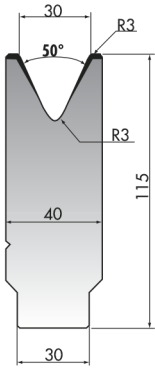

50-30

RKS-07-M115-50-40-1020

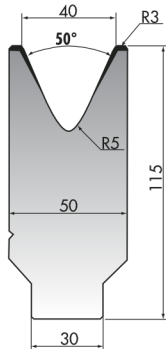

50-40

RKS-07-M115-50-50-1020

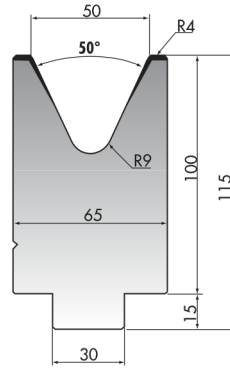

50-50

RKS-07-M115-24-16-1020

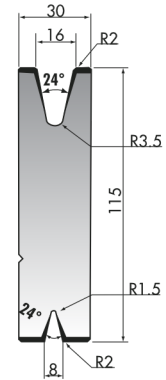

24-16

RKS-07-M115

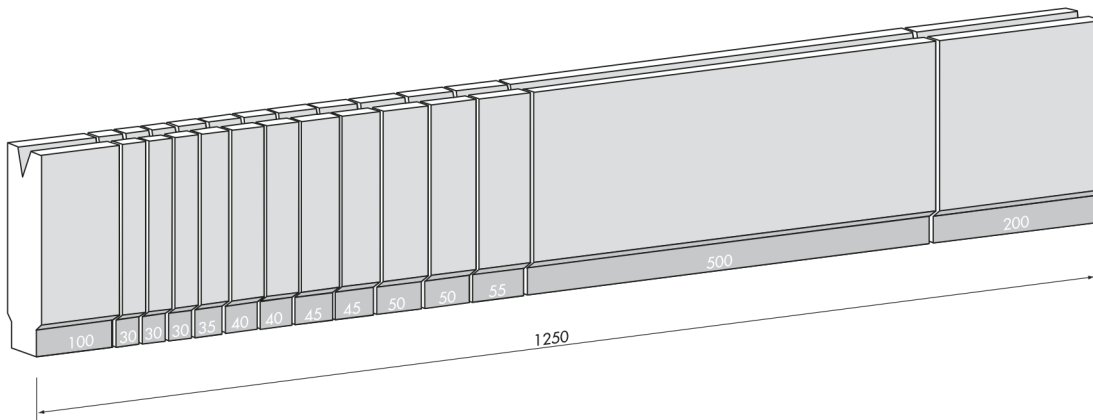

COLLY TYPE

RKS-07-MC112-3050

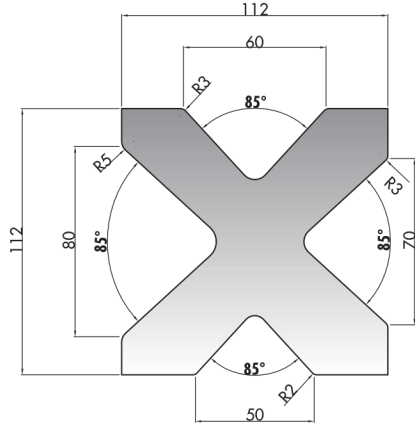

112-3050

	V1	V2	V3	V4
V mm	60	70	50	80
A	85°	85°	85°	85°
R mm	3	3	2	5

RKS-07-MC80-2050-3050

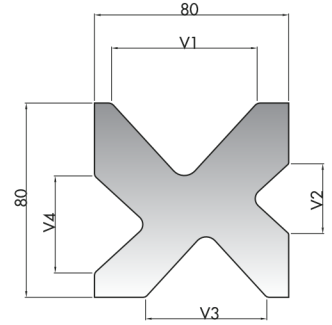

80-2050 / 80-3050

	V1	V2	V3	V4
V mm	60	30	50	40
A	85°	85°	85°	85°
R mm	3	1	2	2

RKS-07-MC74-2050-3050

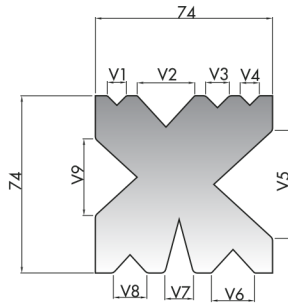

74-2050 / 74-3050

	V1	V2	V3	V4	V5	V6	V7	V8	V9
V mm	8	24	10	8	45	18	12	14	32
A	90°	85°	90°	90°	85°	85°	30°	85°	85°
R mm	0,8	0,8	2	0,8	2	1	2	2	2

RKS-07-MC54-2050-3050

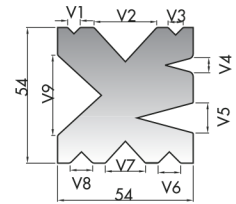

54-2050 / 54-3050

	V1	V2	V3	V4	V5	V6	V7	V8	V9
V mm	5	25	6	6	12	9	16	9	32
A	90°	85°	90°	30°	30°	90°	85°	90°	85°
R mm	0,5	1	0,5	2	0,5	1	0,5	1,5	1

HÄMMERLE - BYSTRONIC TYPE

RKS-09-H11-10-30

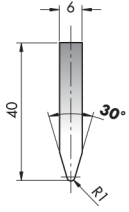

max t/m
10 60

RKS-09-H11-7-30

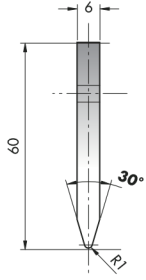

max t/m
7 100

RKS-09-H11-2-30

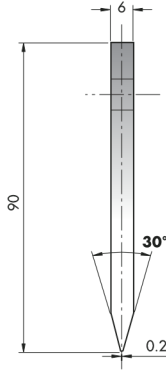

max t/m
2 100

RKS-09-H11-1-30

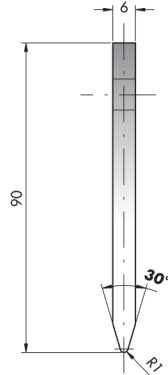

max t/m
1 100

RKS-09-H11-8-30

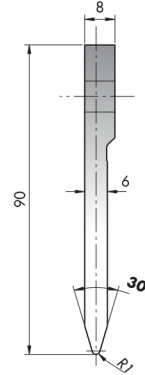

max t/m
8 100

RKS-09-H11-6-30

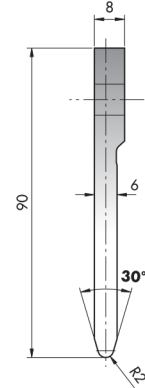

max t/m
6 100

RKS-09-H11-34-30

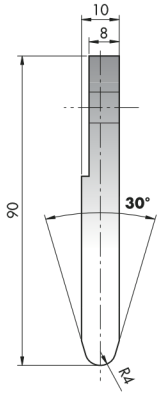

max t/m
34 100

RKS-H11-3-30

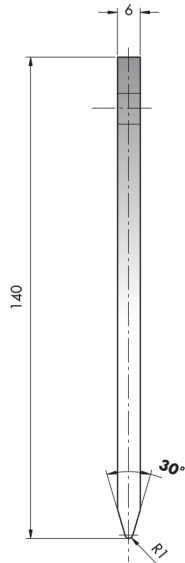

max t/m
3 100

RKS-09-H11-5-90

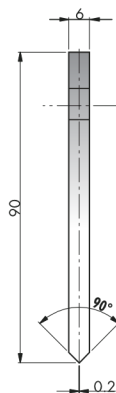

max t/m
5 100

RKS-09-H11-9-90

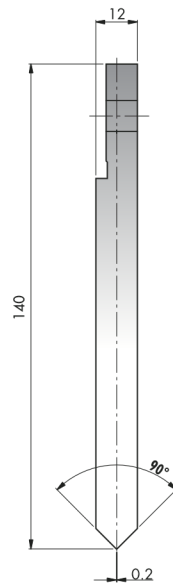

max t/m
9 100

RKS-09-H14-21-90

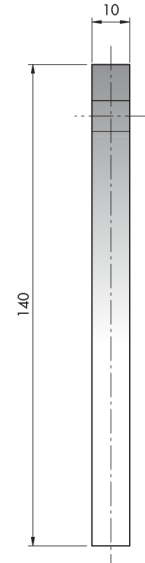

max t/m
21 100

L	
1.01	100
2.01	50
2.02	55
2.03	60
2.04	65
2.05	70
2.06	75
2.07	80
2.08	85
2.09	90
2.10	95
4.01	75 DX
4.02	85 DX
4.03	95 DX
4.04	105 DX
4.05	115 DX
4.06	80 SX
5.01	75 SX
5.02	85 SX
5.03	95 SX
5.04	105 SX
5.05	115 SX
5.06	80 DX

H11-33-1

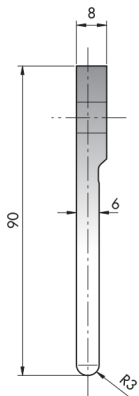

max t/m
31-1 100

H11-35

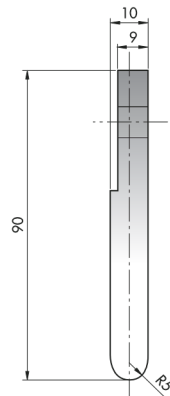

max t/m
35-1 100

RKS-09-H11-36

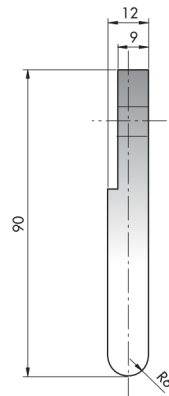

max t/m
36 100

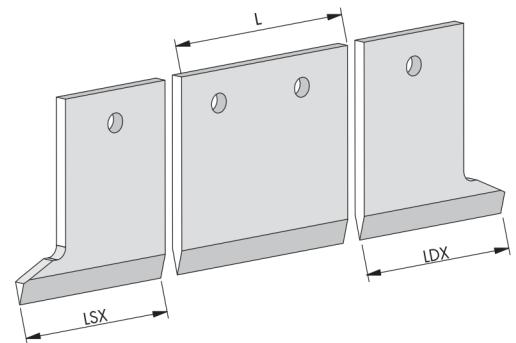

HÄMMERLE - BYSTRONIC TYPE

RKS-09-H41-5-90

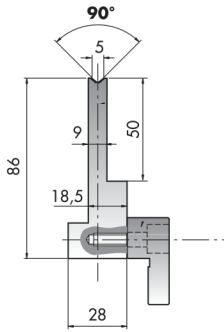

max t/m
41-5 100

RKS-09-H41-7-90

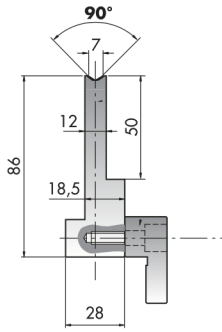

max t/m
41-7 100

RKS-09-H41-10-90

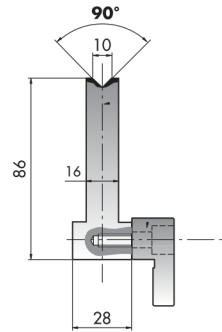

max t/m
41-10 100

RKS-09-H41-12-90

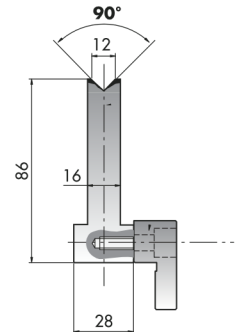

max t/m
41-12 100

RKS-09-H31-10-2

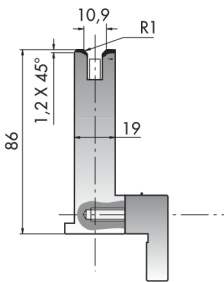

max t/m
10-2 55

RKS-09-H31-32-1

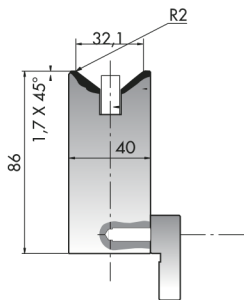

max t/m
32-1 120

RKS-09-H31-21

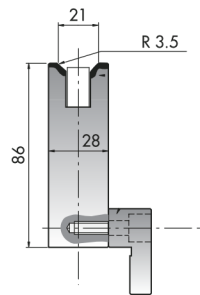

max t/m
21 50

RKS-09-H31-40-1

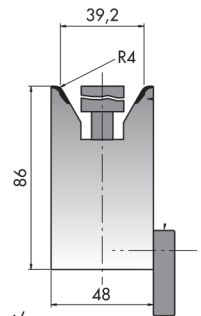

max t/m
40-1 75

RKS-09-H31-110

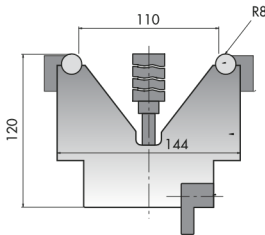

max t/m
110 150

RKS-09-H31-16

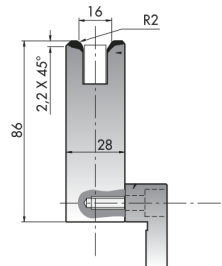

max t/m
16 50

RKS-09-H31-24

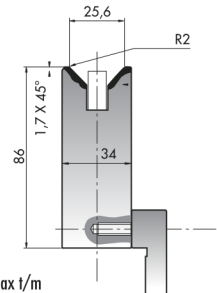

max t/m
24 75

RKS-09-H31-16-1

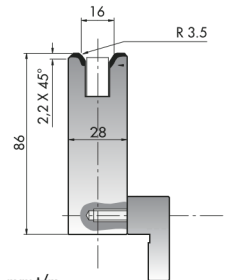

max t/m
16-1 50

RKS-09-H31-60

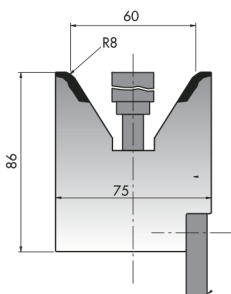

max t/m
60 150

RKS-09-H31-90

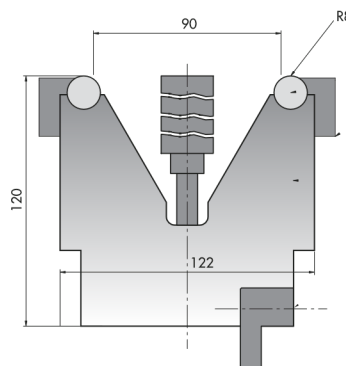

max t/m
90 150

RKS-09-H31-5

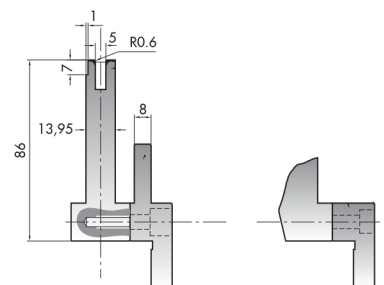

max t/m
5 25

RKS-09-H31-7

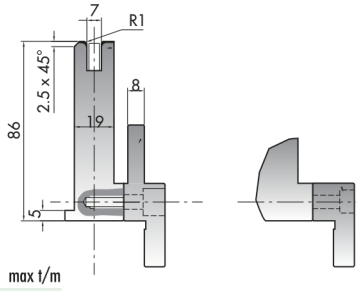

7 50

RKS-09-H31-7-2

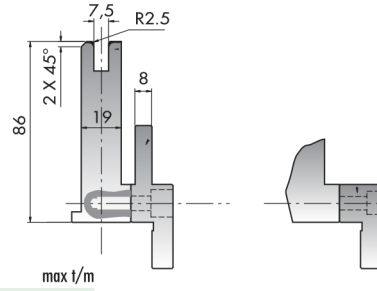

7-2 50

RKS-09-H31-13

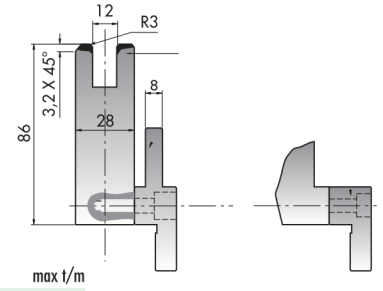

13 50

RKS-09-H31-12

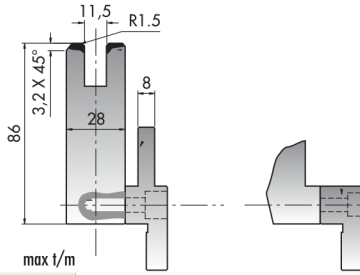

12 50

RKS-09-H31-6

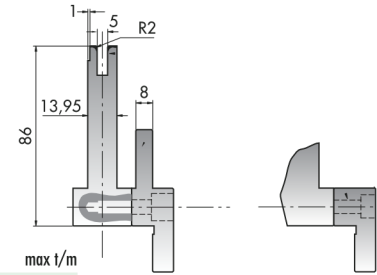

6 35

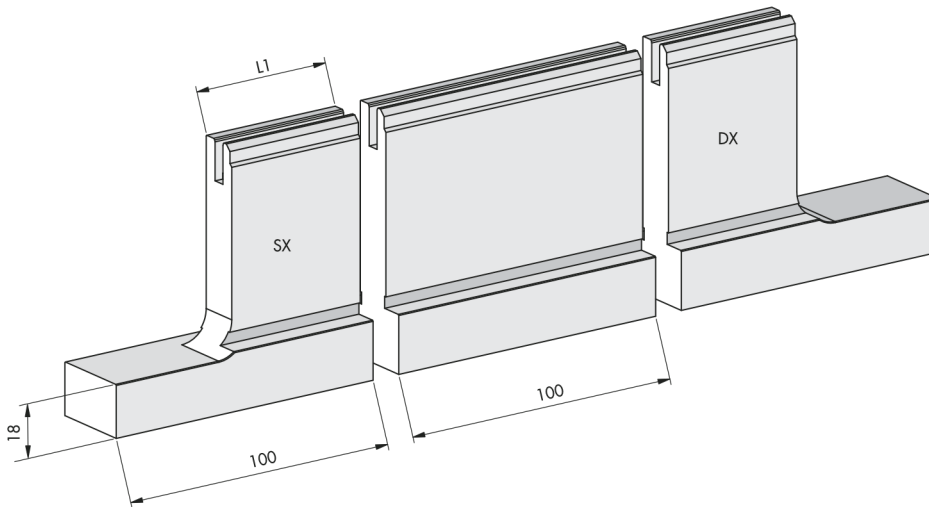

	L	L1
1.01	100	
3.06		50 SX
2.01		55 DX
2.02		60 DX
2.03		65 DX
2.04		70 DX
2.05		75 DX
2.06		80 DX
2.07		85 DX
2.08		90 DX
2.09		95 DX
2.10		50 DX
3.01		55 SX
3.02		60 SX
3.03		65 SX
3.04		70 SX
3.05		75 SX
3.07		80 SX
3.08		85 SX
3.09		90 SX
3.10		95 SX

RKS-09-H22-13

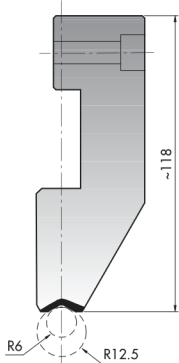

13 100

RKS-09-H22-14

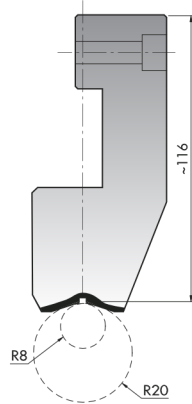

14 100

RKS-09-H22-15

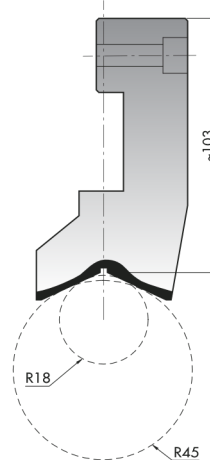

15 100

	L
1.01	100
2.01	50
2.02	55
2.03	60
2.04	65
2.05	70
2.06	75
2.07	80
2.08	85
2.09	90
2.10	95

HÄMMERLE - BYSTRONIC TYPE

RKS-09-H12-14

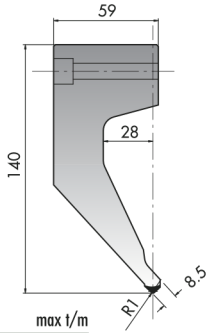

12-14 97,5

RKS-09-H12-52

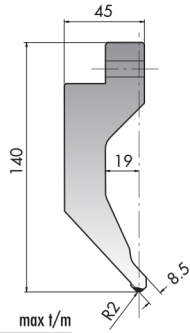

12-52 97,5

RKS-09-H12-53

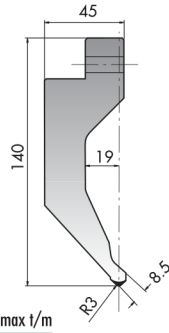

12-53 97,5

RKS-09-H12-19

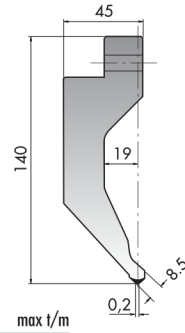

12-19 97,5

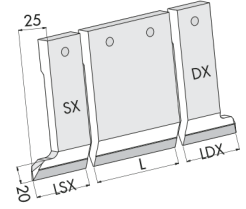

RKS-09-H12-15-85

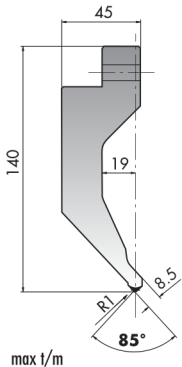

12-14 97,5

RKS-09-H12-25-85

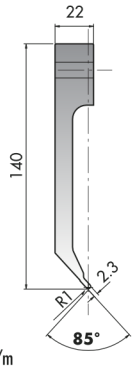

12-52 25

RKS-09-H12-17-55

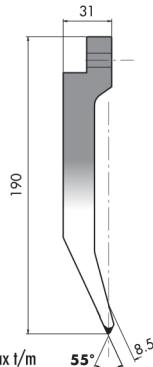

12-53 75

RKS-09-H12-65-50

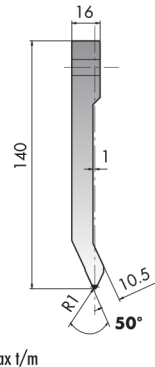

12-19 100

	L
1.01	100
2.01	50
2.02	55
2.03	60
2.04	65
2.05	70
2.06	75
2.07	80
2.08	85
2.09	90
2.10	95
4.01	75 DX
4.02	85 DX
4.03	95 DX
4.04	105 DX
4.05	115 DX
4.06	80 SX
5.01	75 SX
5.02	85 SX
5.03	95 SX
5.04	105 SX
5.05	115 SX
5.06	80 DX

RKS-09-H21-3

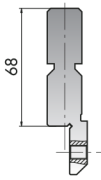

21-3 100

RKS-09-H21-2

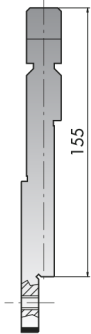

21-2 100

RKS-09-H21-4

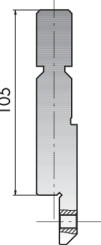

21-4 100

RKS-09-H21-5

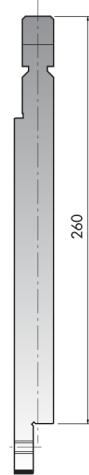

12-5 100

RKS-09-H21-10

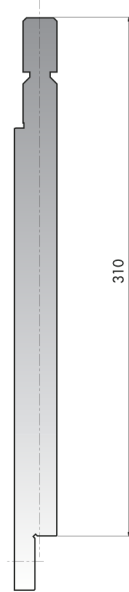

12-10 100

	L
1.01	100
1.03	200
2.01	50
2.02	55
2.03	60
2.04	65
2.05	70
2.06	75
2.07	80
2.08	85
2.09	90
2.10	95
4.01	75 DX
4.02	85 DX
4.03	95 DX
4.04	105 DX
4.05	115 DX
4.06	80 SX
5.01	75 SX
5.02	85 SX
5.03	95 SX
5.04	105 SX
5.05	115 SX
5.06	80 DX

RKS-09-H22-6

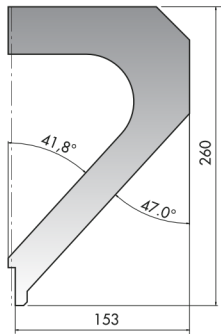

22-6 60

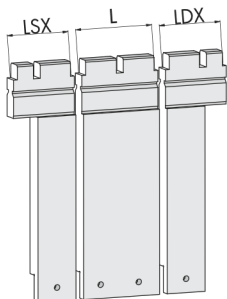

SPECIAL TOOLS

RKS-SP-SPE-1

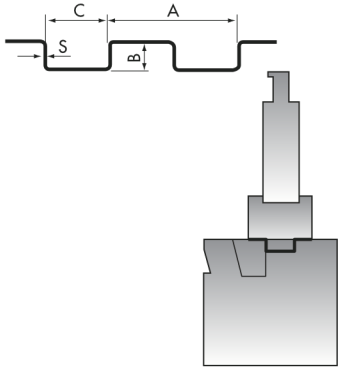

1

RKS-SP-SPE-2

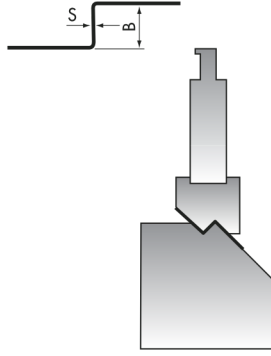

2

RKS-SP-SPE-3

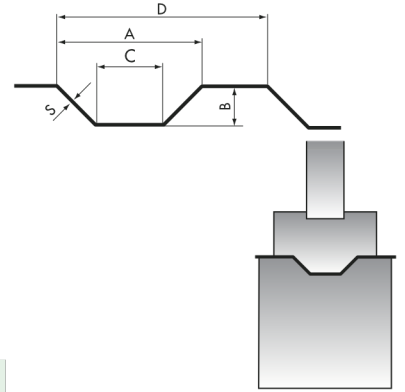

3

RKS-SP-SPE-4

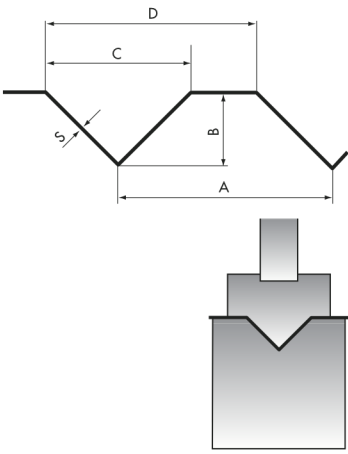

4

RKS-SP-SPE-5

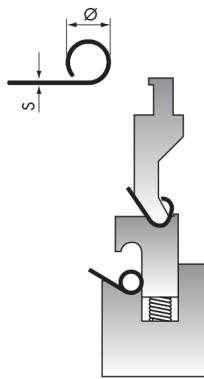

5

RKS-SP-SPE-6

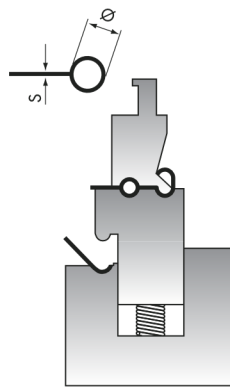

6

RKS-SP-SPE-7



7

RKS-SP-SPE-8



8

RKS-SP-SPE-9

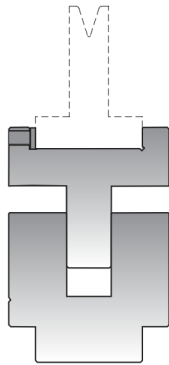

9

RKS-SP-SPE-10



10

RKS-SP-SPE-11

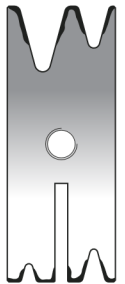

11

RKS-SP-SPE-12

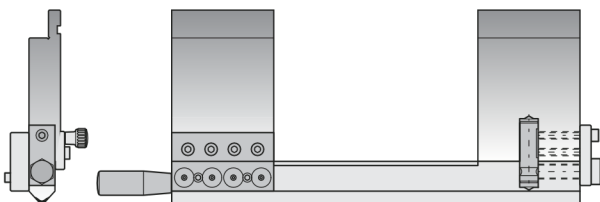

12

RKS-SP-SCA-M

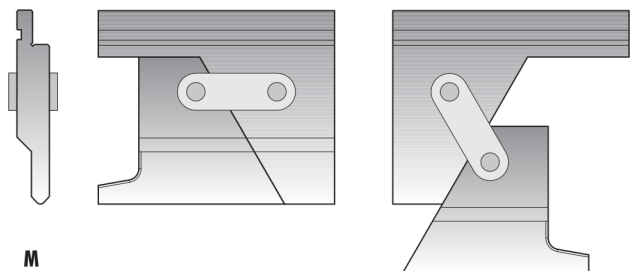

M

SPECIAL TOOLS

RKS-SP-SPE-P1

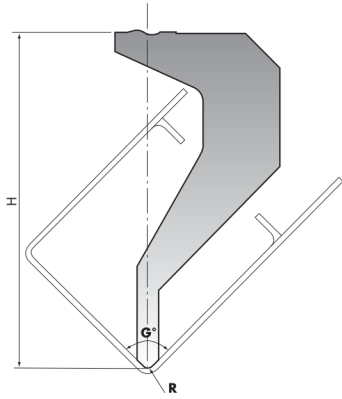

RKS-SP-SPE-P2

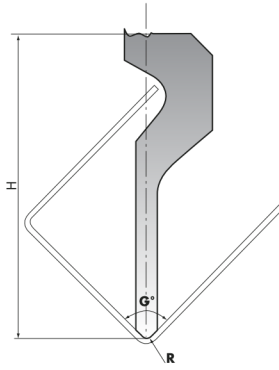

RKS-SP-SPE-P3

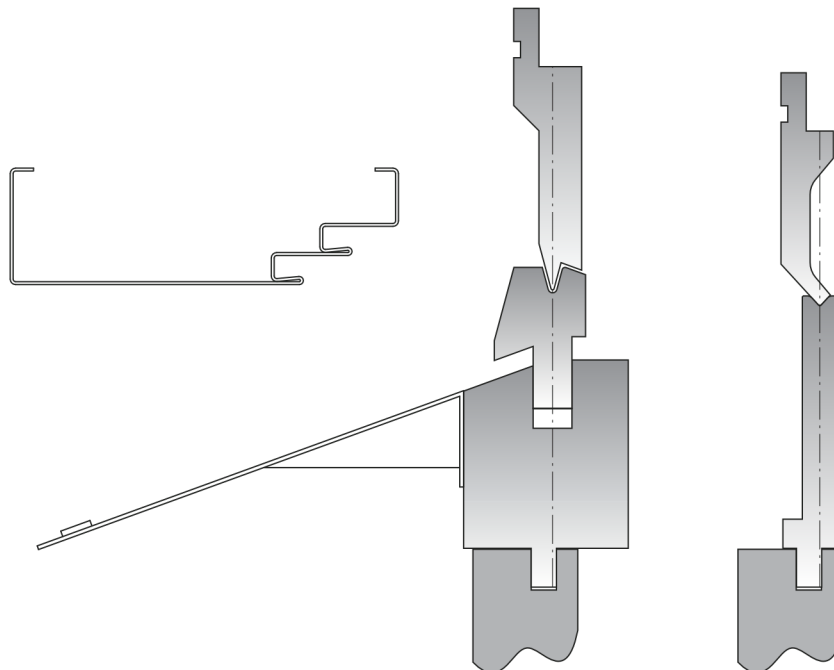
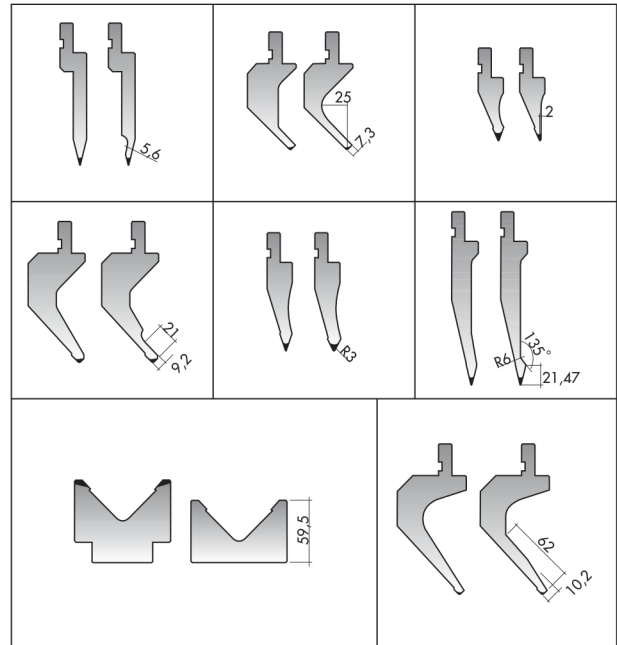
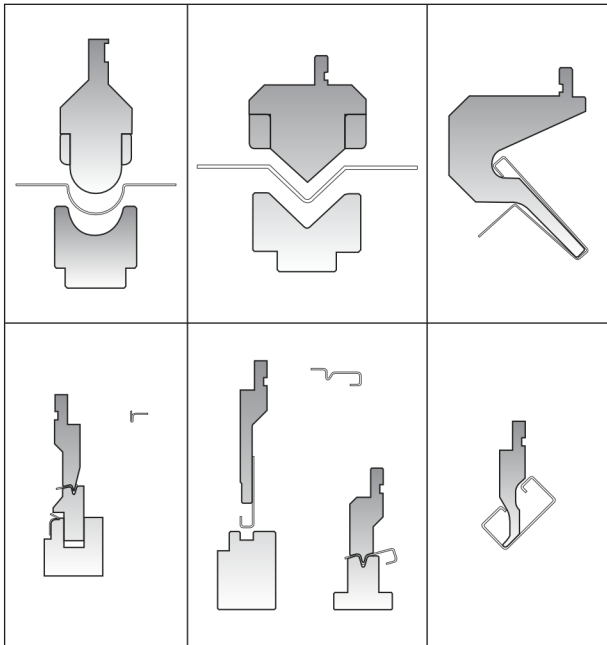
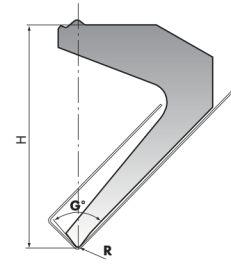

RKS-SP-MR90-(20-24-30-40-50-60-70)-78-835

	V mm	B mm	C mm
20-78	20	45	6
24-78	24	49	6
30-78	30	60	8
40-78	40	70	8
50-78	50	84	10
60-78	60	94	10
70-78	70	104	10

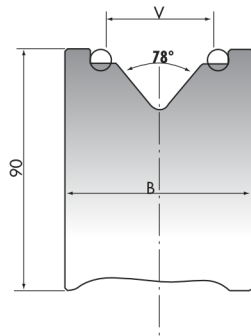

RKS-SP-MR130-(20-24-30-40-50-60-75-80-90-100-120)-78-835

	V mm	B mm	C mm
20-78	20	45	6
24-78	24	49	6
30-78	30	60	8
40-78	40	70	8
50-78	50	84	10
60-78	60	94	10
75-78	75	118	16
80-78	80	123	16
90-78	90	133	16
100-78	100	143	16
120-78	120	163	16

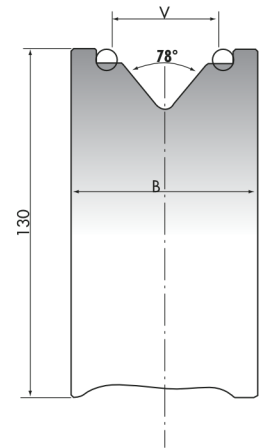

RKS-SP-A10

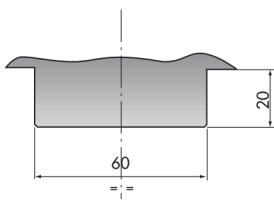

10

RKS-SP-A11

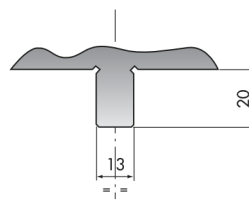

11

RKS-SP-A13

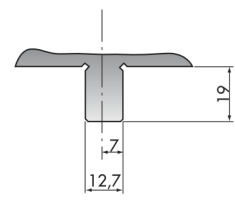

13

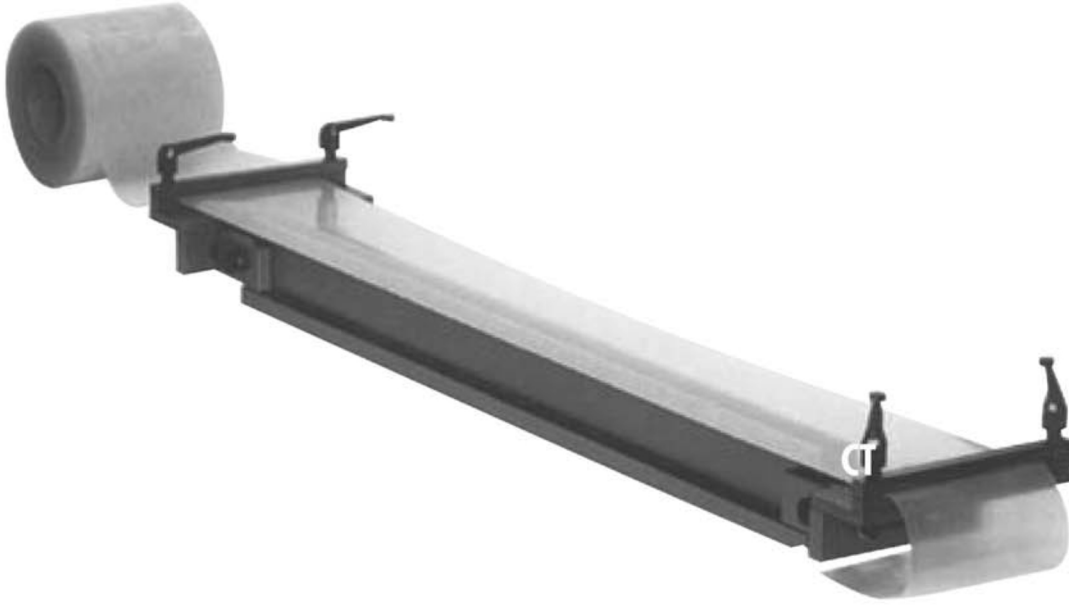

SHEAR BLADES

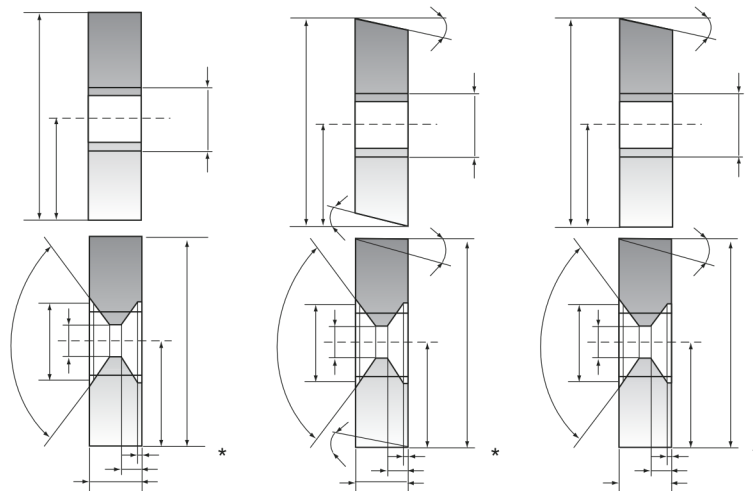
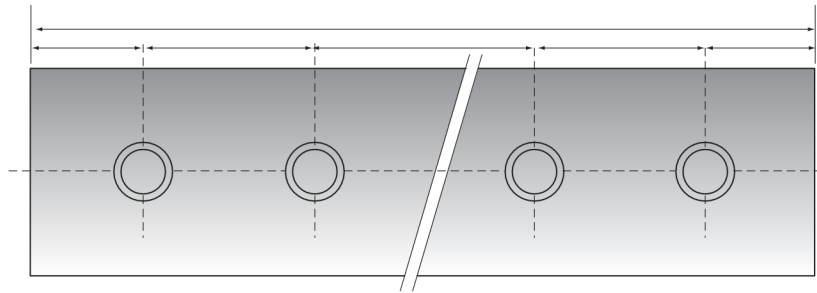
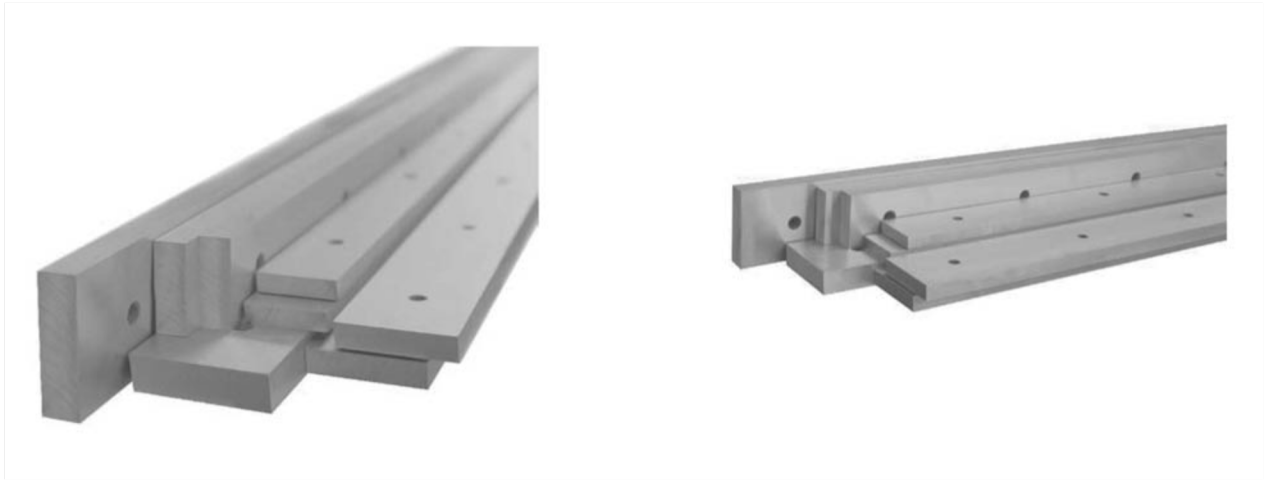

RETROFITTING

RKS-RT-C-200-2500-3000-4000/S

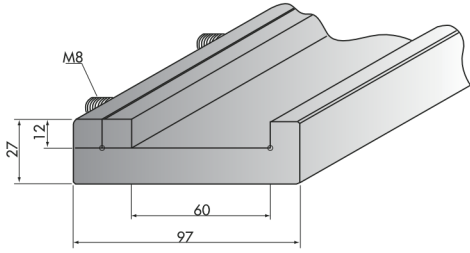

mm	
2000/S	2100
2500/S	2600
3000/S	3100
4000/S	4100

RKS-RT-C-1050/R

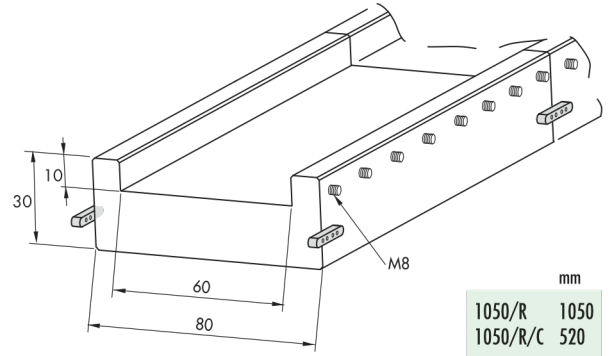

mm	
1050/R	1050
1050/R/C	520

RKS-RT-C-1050/RS

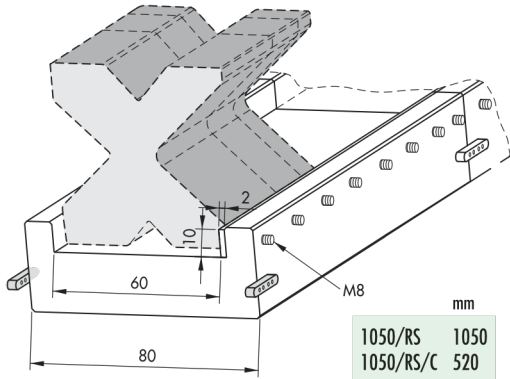

mm	
1050/RS	1050
1050/RS/C	520

RKS-RT-C-1050-90

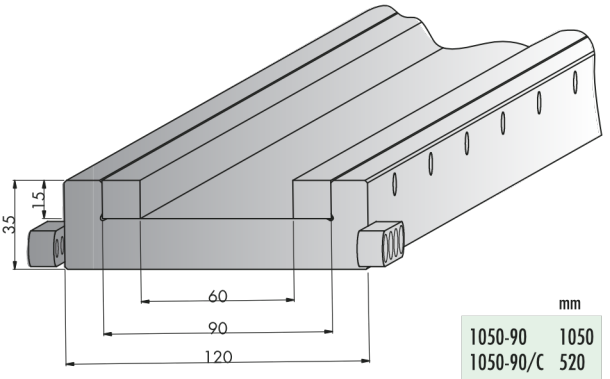

mm	
1050-90	1050
1050-90/C	520

RKS-RT-INT35

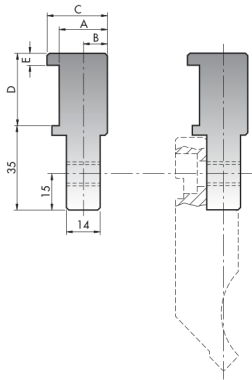

mm	
35	835
35/C	415
35/F	805

RKS-RT-INT100-150

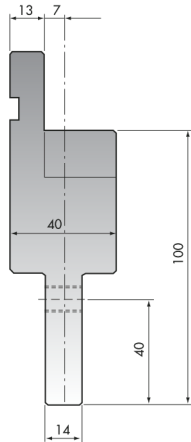

max t/m	
100	100

RKS-RT-INT120-150

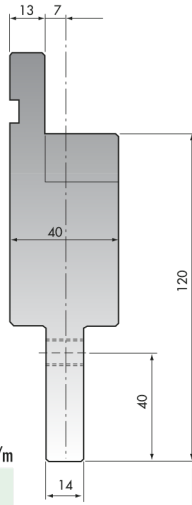

max t/m	
120	100

RKS-RT-INT120-40-150

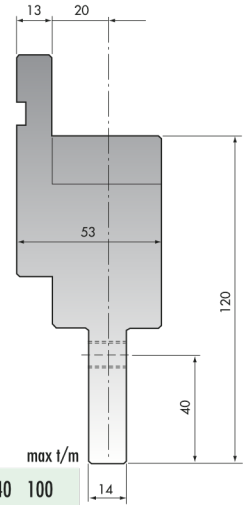

max t/m	
120-40	100

RKS-RT-INT100 FISSO-150

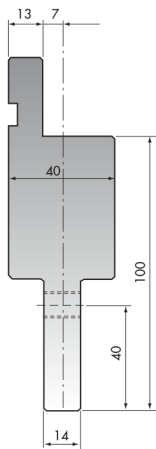

max t/m	
FISSO	100

RKS-RT-INT150-150

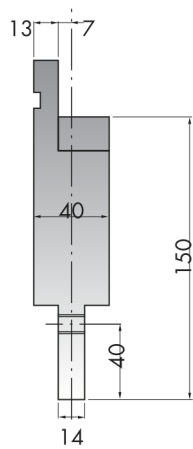

max t/m	
150	100

RKS-RT-INT67-79-835-415

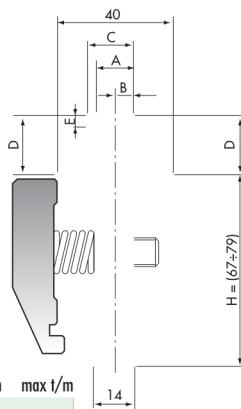

mm		max t/m	
67-79	835	100	
67-79/C	415	100	

RKS-RT-INT80-100-835-415

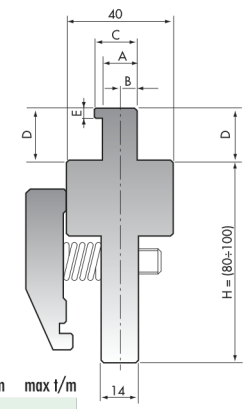

mm		max t/m	
80-100	835	100	
80-100/C	415	100	

RETROFITTING

RKS-RT-00-01-INT100-N-150

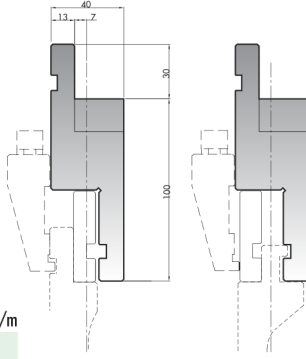

max t/m

100-N 100

RKS-RT-00-INT100-A-150

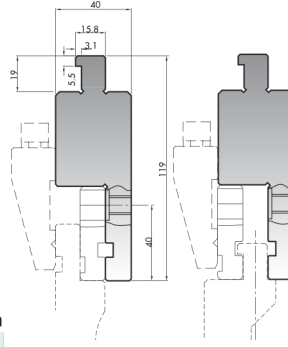

max t/m

100-A 100

RKS-RT-01-INT100-A-150

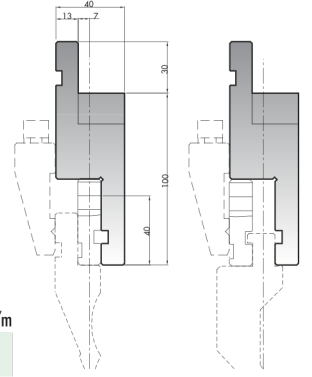

max t/m

100-A 100

RKS-RT-06-01-AD1-(A-B-C-D)-150

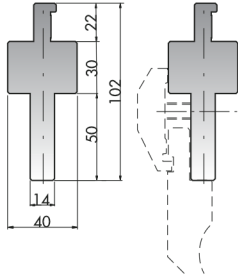

max t/m

A 100
B 100
C 100
D 100

RKS-RT-03-01-AD3-150

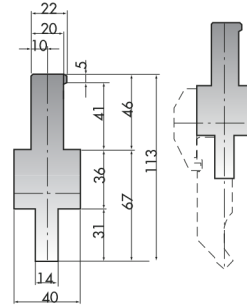

max t/m

3 100

RKS-RT-01-AD4-150

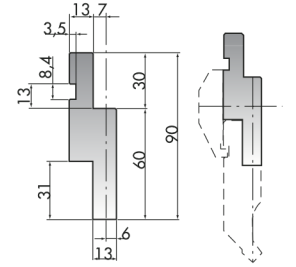

max t/m

4 100

RKS-RT-03-01-AD10-150

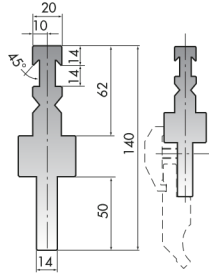

max t/m

10 100

RKS-RT-02-01-AD11-150

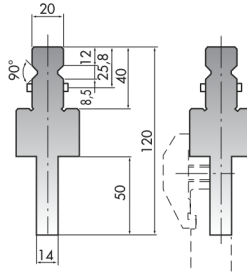

max t/m

11 100

RKS-RT-05-01-AD12-150

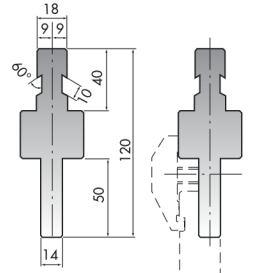

max t/m

12 100

RKS-RT-01-AD13-150

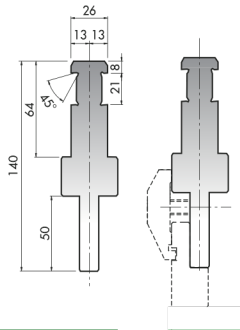

max t/m

13 100

RKS-RT-04-01-AD14-150

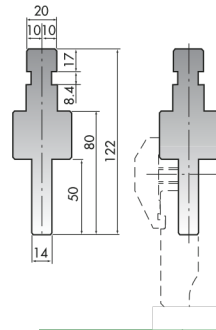

max t/m

14 100

RKS-RT-08-01-AD15-150

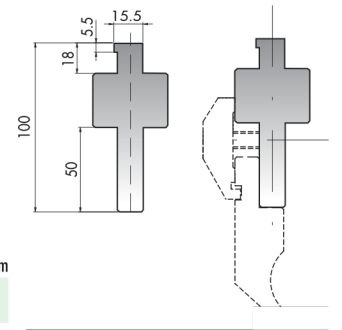

max t/m

15 100

RKS-RT-00-01-AD16-150

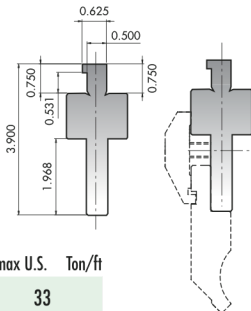

max U.S. Ton/ft

16 33

RKS-RT-00-06-AD19-A-150

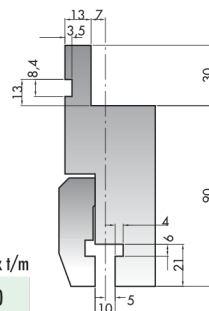

max t/m

19-A 100

RKS-RT-01-06-AD20-150

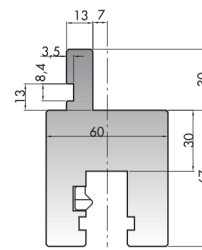

max t/m

20 100

RKS-RT-02-AD21-150

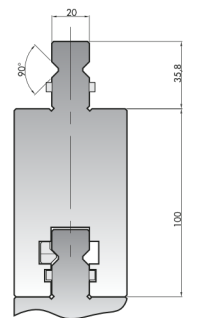

max t/m

21 150

RETROFITTING

RKS-RT-00-INT35-A-835-415-805

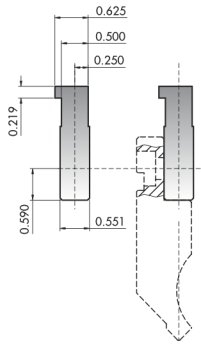

mm
35-A 835
35-A/C 415
35-A/F 805

RKS-RT-ADX-150

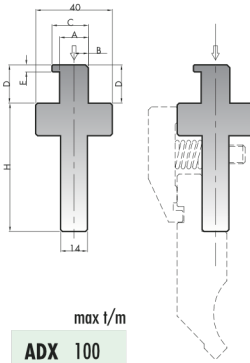

max 1/m
ADX 100

RKS-RT-STANDARD

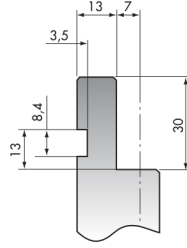

RKS-RT-A1

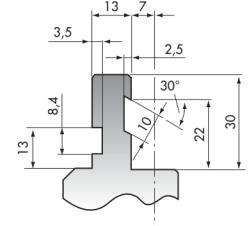

A1

RKS-RT-A6

RKS-RT-A41

RKS-RT-A7

RKS-RT-A8

RKS-RT-A9

RKS-RT-A42

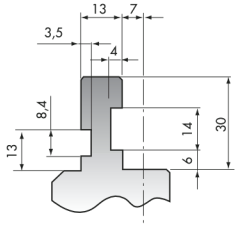

A6

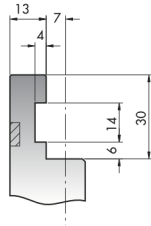

A41

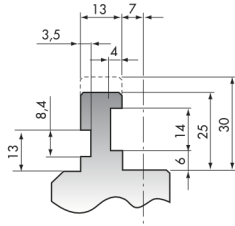

A7

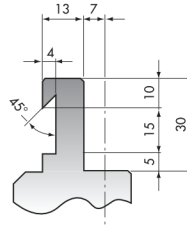

A8

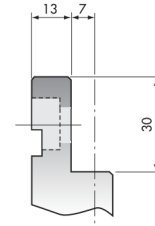

A9

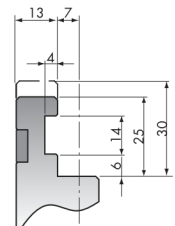

A42

RKS-RT-01-CTS60-835-415

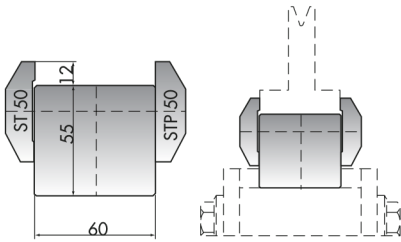

mm
60 835
60/C 415

RKS-RT-01-02-03-AD5-1000-500

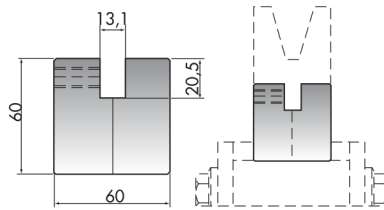

mm
5 1000
5/C 500

RKS-01-02-03-AD6-1000-500

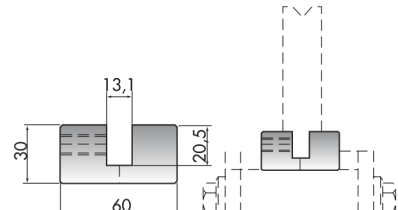

mm
6 1000
6/C 500

RKS-RT-02-03-01-AD7-835-415

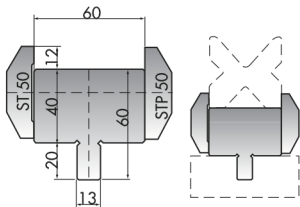

mm
7 835
7/C 415

RKS-RT-06-02-03-AD8-1000-500

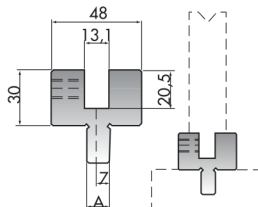

A mm
8 12
8-12.7 12,7

RKS-RT-06-01-AD9-835-415

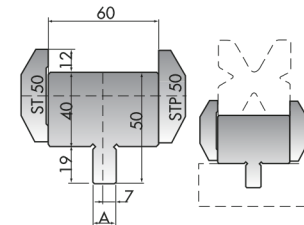

A mm
9 12
9-12.7 12,7

RETROFITTING

RKS-RT-00-01-AD17-835-415

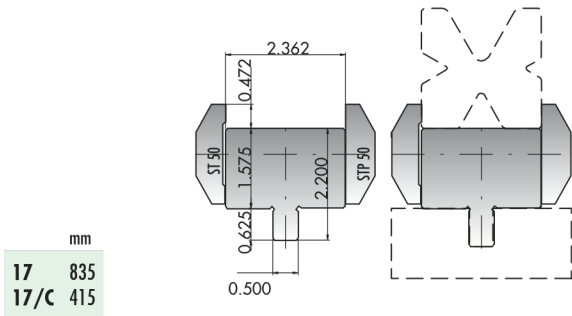

RKS-RT-00-01-AD18-835-415

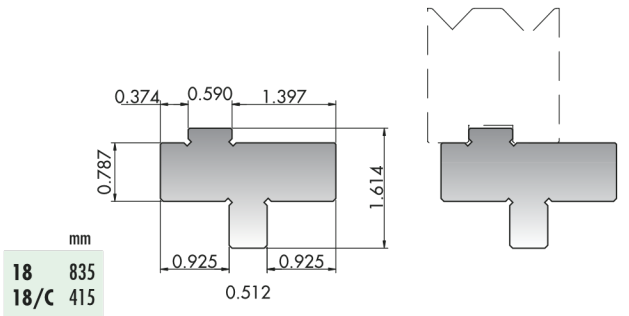

RKS-RT-02-03-01-A30-835-415-805

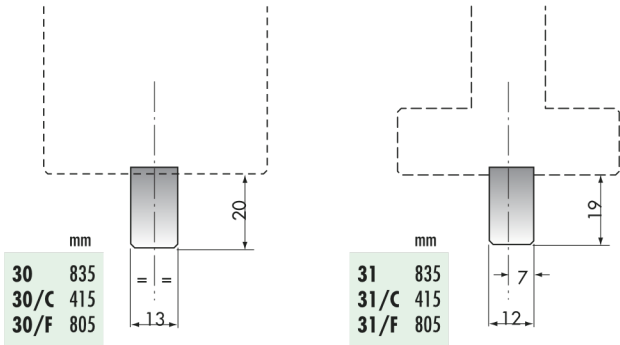

RKS-RT-06-01-A32-835-415-805

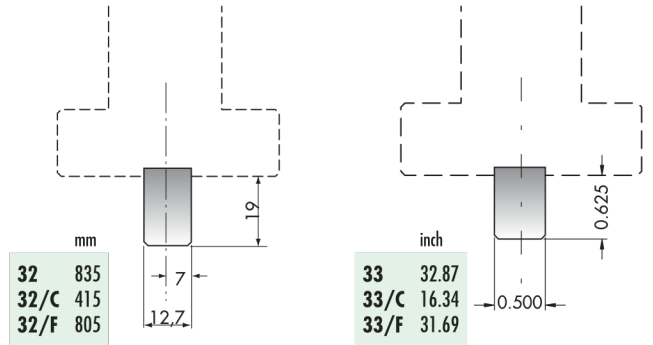

RKS-RT-00-01-A33-835-415-805

RKS-RT-(ST50-ST50R-STG50)-150

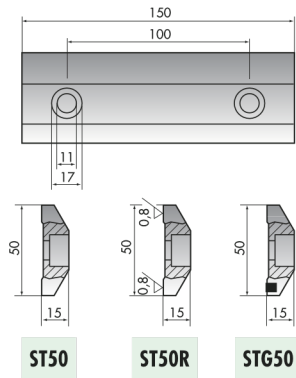

RKS-RT-(ST60-ST60R-STG60)-150

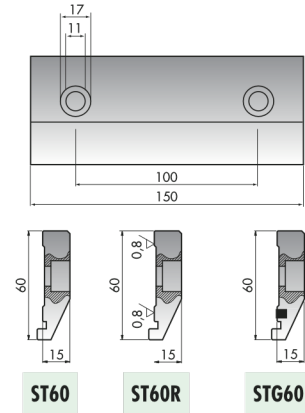

RKS-RT-(STL60-STL60R-STLG60)-150

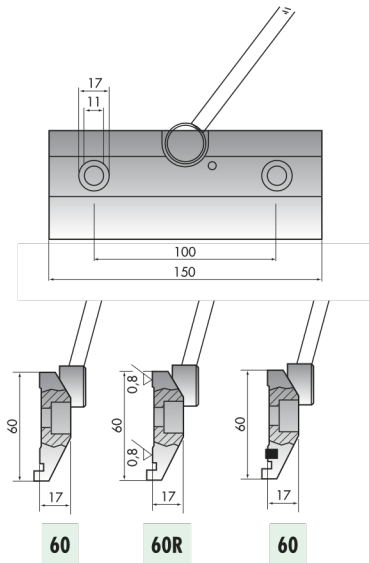

RKS-RT-(STX60-STX60R-STXG60)-150

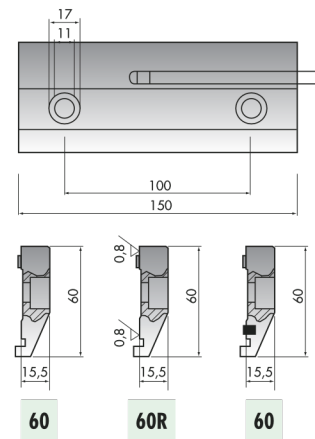

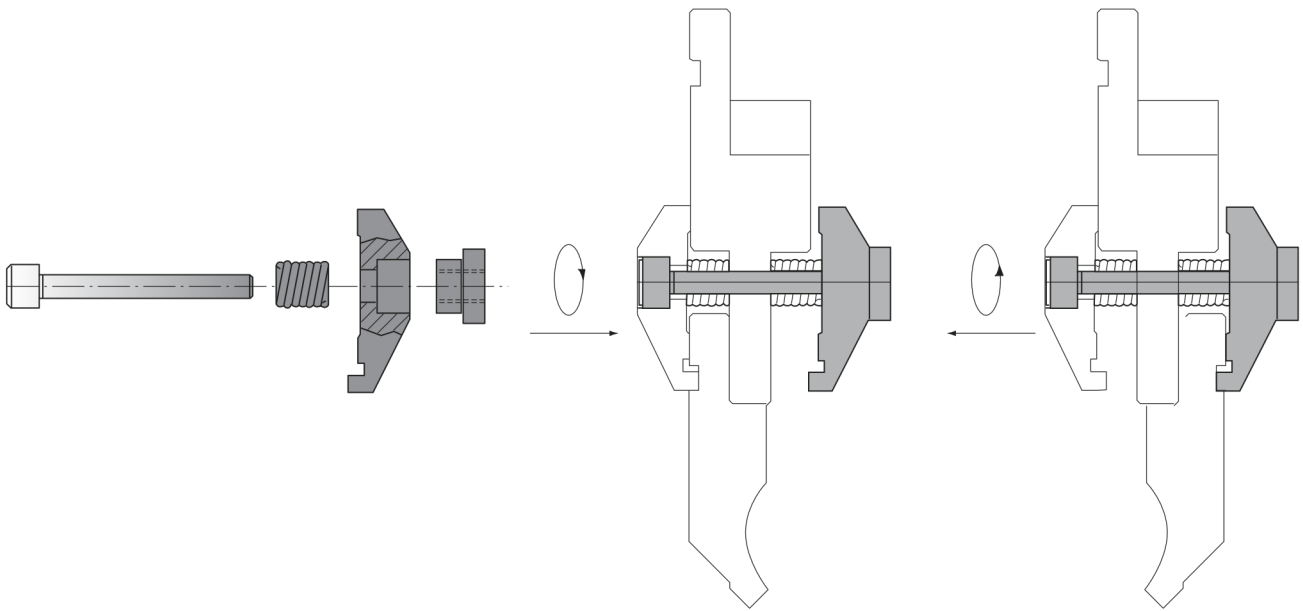



Created With Love

EAST GATE PROJECT MAKİNE SANAYİ TİCARET LİMİTED ŞİRKETİ

ADRES: İhlamurkuyu Mah. Didenur Sk. No:1/7 34771 Ümraniye / İSTANBUL

TEL: +90 507 651 36 66 WEB: www.egp-universe.com